



GSA prices effective April 2, 2018
(based on February 6, 2017, commercial price list)
Published July 2018

Storage Systems

Tu® Metal Storage

**General Services Administration
Federal Supply Service
Authorized Federal Supply Schedule Price List**

Online access to contract ordering information, terms and conditions, up-to-date pricing, and the option to create an electronic delivery order is available through GSA Advantage!®, a menu-driven database system. The Internet address for GSA Advantage! is www.gsaadvantage.gov.

Office Furniture
FSC Group 71, Part 1
Contract Number: GS-03F-036DA
Contract Period: December 21, 2015—December 20, 2020

Herman Miller, Inc.
855 East Main Avenue
Zeeland, Michigan 49464
(616) 654 3000 Phone
(616) 654 8278 Fax
www.HermanMiller.com/government

Business Size: Large

Contract Information

1a. Special Item Numbers (SIN)

SIN 71-1
Packaged Offices

SIN 711-1
Furniture Systems

SIN 711-2
Computer Furniture

SIN 711-3
Filing and Storage Cabinets

SIN 711-11
Tables and Accessories

SIN 711-16
Upholstered Seating

SIN 711-18
Multi-Purpose Seating

SIN 711-91
Project Management

Services under this SIN may be used only in conjunction with the purchase of new furniture. Please contact your local Herman Miller representative to discuss the available labor categories (listed below). The hourly rates listed are "Not To Exceed" or "NTE" values.

Furniture Project Manager: \$64.75 per hour
Furniture Project Coordinator: \$49.00 per hour
Build-Out Project Manager: \$80.00 per hour

SIN 711-93
Reconfiguration and Relocation Services

Reconfiguration and Relocation Services will be provided by Herman Miller, Inc., or its participating dealer based on a fee not to exceed \$55 per hour, which applies to services totaling \$150,000 (per SIN) and below only. Services above \$150,000 shall be negotiated on a case-by-case basis. This SIN may only be used with the purchase of new product under SIN 711-1.

See * Additional Notes for Installation & Reconfiguration and Relocation Services.

SIN 711-94
Design/Layout

Design service will be provided by Herman Miller, Inc., or its participating dealer based on a fee not to exceed \$65 per hour.

SIN 711-95

Installation Services

Installation Services will be provided by Herman Miller, Inc., or its participating dealer based on a fee not to exceed \$55 per hour (\$82.50 per hour for after-hours Installation), which applies to services totaling \$150,000 (per SIN) and below only. Services above \$150,000 shall be negotiated on a case-by-case basis.

See * Additional Notes for Installation & Reconfiguration and Relocation Services.

* Additional Notes for Installation & Reconfiguration and Relocation Services:

FOB Destination (Drop Ship): Price includes product delivery to the site, brought to the tailgate of the truck. The purchaser is responsible for unloading.

Prices effective up to the maximum order by SIN only. Above the MO, pricing shall be negotiated on a case-by-case basis between the client and local dealer.

Standard Services are Subject to the Following Conditions:

Installation will be performed during normal weekday working hours.

Adequate facilities for delivery, unloading, moving and staging/ storing the product during the installation process shall be provided.

Service work will not be hindered by other trades.

Electric, heat, and adequate elevator service will be furnished without charge.

The immediate installation area shall be complete and free of debris including the carpet/flooring before installation commences.

Any work requiring a licensed electrician is the responsibility of the buyer.

Additional Charges May Apply For:

Major Metro Markets and any non-ground floor installation.

Major Metro Markets include large population centers and urban environments.

Installation in a clinical/medical environment.

Special restrictions or limits established by local laws, ordinances or the directions of the buyer, including but not limited to restrictions on transportations of materials, street access to the job site and/or dock facilities.

Installations outside of a 50 mile radius of the servicing dealer.

Local Prevailing Wage and/or Union Labor Rates.

Any additional charges shall be quoted by the dealer and approved by the buyer prior to performance of the work.

SIN 711-96

Leasing

Contact Herman Miller participating government dealer for current leasing information.

SIN 711-99

New Product Introductions

Contract Information

continued

1b. Lowest Priced Model

SIN 711-1:	G9999.B	\$7
SIN 711-2:	6-5-D	\$35
SIN 711-3:	9M10018	\$14
SIN 711-11:	DT9A.	\$36
SIN 711-16:	OA401	\$41
SIN 711-18:	AS90598	\$46
SIN 711-99:	R1366	\$27

1c. Not applicable

2. Maximum Order

SIN 711-1, SIN 711-2
\$500,000 net product value

SIN 711-3, SIN 711-11
\$300,000 net product value

SIN 711-16, SIN 711-18
\$200,000 net product value

SIN 711-93
\$150,000

SIN 711-94
\$150,000

SIN 711-95
\$150,000

SIN 711-96
\$500,000 net product value

SIN 711-99
\$50,000 net product value

3. Minimum Order

\$100 net

4. Geographic Coverage

Continental U.S.

Orders for Alaska, Hawaii, and Puerto Rico will be shipped F.O.B. inland carrier point of exportation.

5. Point of Production

Zeeland, Ottawa County, Michigan
Spring Lake, Ottawa County, Michigan

6. Pricing

Prices shown are list. Discounts include Industrial Funding Fee.

SIN 711-1

Product: Selected Action Office 1, Action Office 2, C-Style Overhead Storage, Ethospace System, Quadrant Pedestals, Supplemental Products, Tu Pedestals and Pedastools, and approved Herman Miller Options Products.

Standard Lead Time	Single Order Net Purchase	Discount From list
	\$100 - 250,000	73.8%
	\$250,001 - 500,000	76.8%

SIN 711-1

Product: Selected Renew™ Tables, Renew Link and approved Herman Miller Options Products

Standard Lead Time	Single Order Net Purchase	Discount From List
	\$100 - 500,000	72.8%

SIN 711-1

Product: Selected Motia™ Tables, and approved Herman Miller Options Products

Standard Lead Time	Single Order Net Purchase	Discount From List
	\$100 - 500,000	73.8%

SIN 711-1

Product: Tu Wood Pedestals and approved Herman Miller Options Products

Standard Lead Time	Single Order Net Purchase	Discount From List
	\$100 - 300,000	74.3%

SIN 711-1

Product: Selected Canvas Office Landscape and approved Herman Miller Options Products

Standard Lead Time	Single Order Net Purchase	Discount From List
	\$100 - 500,000	74.8%

SIN 711-1

Product: Selected Layout Studio® and approved Herman Miller Options Products

Standard Lead Time	Single Order Net Purchase	Discount From List
	\$100 - 500,000	60.7%

SIN 711-1

Product: Selected Meridian Pedestals, Meridian Pedastools, and approved Herman Miller Options Products

Standard Lead Time	Single Order Net Purchase	Discount From List
	\$100 - 500,000	64.2%

Contract Information

continued

SIN 711-1

Product: Selected Thrive Portfolio and approved Herman Miller Options Products

Standard Lead Time	Single Order Net Purchase	Discount From List
	\$100 - 250,000	62%
	\$250,001 - 500,000	66.4%

SIN 711-2

Product: Passage Desking System and approved Herman Miller Options Products

Standard Lead Time	Single Order Net Purchase	Discount From List
	\$100 - 500,000	56.7%

SIN 711-2

Product: 5000 Series Furniture and approved Herman Miller Options Products

Standard Lead Time	Single Order Net Purchase	Discount From List
	\$100 - 500,000	58.7%

SIN 711-3

Product: Meridian Laterals, Verticals, Towers, and Storage products and approved Herman Miller Options Products

Standard Lead Time	Single Order Net Purchase	Discount From List Laterals	Verticals	Towers & Storage
	\$100 - 300,000	67.3%	66.3%	62.7%

SIN 711-3

Product: Tu Lateral Files, Tu Storage, Tu Towers, Tu Wood Cases, Tu Wood Cubbies, Tu Wood Credenzas, Tu Wood Towers, and approved Herman Miller Options Products

Standard Lead Time	Single Order Net Purchase	Discount From List
	\$100 - 300,000	74.3%

SIN 711-11

Product: Selected Tables and Accessories and approved Herman Miller Options Products

Standard Lead Time	Single Order Net Purchase	Discount From List
Avive® Tables	\$100 - 250,000	72.8%
	\$250,001 - 500,000	74.8%
Herman Miller Eames® Tables	\$100 - 250,000	73.6%
	\$250,001 - 300,000	77.6%
Everywhere™ Tables	\$100 - 300,000	72.8%

SIN 711-16

Product: Swoop upholstered seating products and approved Herman Miller Options Products

Standard Lead Time	Single Order Net Purchase	Discount From List
Swoop™	\$100 - 200,000	60.7%

SIN 711-18

Product: Selected Seating and approved Herman Miller Options Products

Standard Lead Time	Single Order Net Purchase	Discount From List
Aeron® (Classic and New)	\$100 - 200,000	64.5%
Aside®	\$100 - 200,000	64.2%
Caper®	\$100 - 200,000	61.5%
Celle®	\$100 - 200,000	59.7%
Embody®	\$100 - 200,000	59.7%
Equa 2®	\$100 - 200,000	65.8%
Ergon 3®	\$100 - 200,000	68.8%
Keyn	\$100 - 200,000	57.7%
Mirra® 2	\$100 - 200,000	61.7%
Setu®	\$100 - 200,000	59.7%
Sayl®	\$100 - 200,000	62.2%
Verus™	\$100 - 200,000	63.7%

SIN 711-99

Product: Selected Exclave™, Locale®, Public Office Landscape®, Resolve® System, and approved Herman Miller Options Products

Standard Lead Time	Single Order Net Purchase	Discount From List
Exclave	\$100 - 50,000	61.7%
Locale	\$100 - 50,000	63.7%
Public Office Landscape	\$100 - 50,000	61.7%
Resolve System	\$100 - 50,000	69.8%
Intent Solution	\$100 - 50,000	58.7%

7. Quantity Discounts

Reference item #6.

8. Payment Term

Net 30 days

9. Government Commercial Credit Card

- Government commercial credit cards are accepted below the micropurchase threshold.
- Government commercial credit cards are accepted above the micropurchase threshold.

10. Foreign Items

None

11. Time of Delivery

- 90 day ARO
- Expedited delivery: Items listed in the 10-Day section of the catalogs are available for expedited delivery.
- Overnight/2-day delivery: Select items may be available for overnight or 2-day delivery. Contact Herman Miller or a participating dealer for availability and rates.
- Urgent requirements: Agencies may contact contractor or participating dealer to request faster delivery.

Contract Information

continued

12. F.O.B.

F.O.B. destination except Alaska, Hawaii, and Puerto Rico, which will be shipped F.O.B. inland carrier point of exportation.

13. Ordering Address

- a. Herman Miller, Inc.,
Government Customer Care 0161
855 East Main Avenue
Zeeland MI 49464.
- b. For supplies and services, the ordering procedures information on Blanket Purchase Agreements (BPA's) and a sample BPA can be found at the GSA/FSS Schedule homepage (www.fss.gsa.gov/schedules).

14. Payment Address.

Herman Miller, Inc.
22764 Network Place
Chicago, IL 60673-1227

15. Warranty

Herman Miller, Inc., commercial warranty applies.

16. Export Packing Charge

Prices supplied on request.

17. Terms and Conditions of Government Purchase Card Acceptance

(any thresholds above the micropurchase level)
None.

18. Rental Maintenance and Repair Terms

Not applicable

19. Terms and Conditions of Installation

Installation Services will be provided by Herman Miller, Inc., or its participating dealer based on a fee not to exceed \$55 per hour (\$82.50 per hour for after-hours Installation), which applies to services totaling \$150,000 (per SIN) and below only. Services above \$150,000 shall be negotiated on a case-by-case basis.

Additional Notes for Installation & Reconfiguration and Relocation Services:

FOB Destination (Drop Ship): Price includes product delivery to the site, brought to the tailgate of the truck. The purchaser is responsible for unloading.

Prices effective up to the maximum order by SIN only. Above the MO, pricing shall be negotiated on a case-by-case basis between the client and local dealer.

Standard Services are Subject to the Following Conditions:

Installation will be performed during normal weekday working hours.

Adequate facilities for delivery, unloading, moving and staging/storing the product during the installation process shall be provided.

Service work will not be hindered by other trades.

Electric, heat, and adequate elevator service will be furnished without charge.

The immediate installation area shall be complete and free of debris including the carpet/flooring before installation commences.

Any work requiring a licensed electrician is the responsibility of the buyer.

Additional Charges May Apply For:

Major Metro Markets and any non-ground floor installation.

Major Metro Markets include large population centers and urban environments.

Installation in a clinical/medical environment.

Special restrictions or limits established by local laws, ordinances or the directions of the buyer, including but not limited to restrictions on transportations of materials, street access to the job site and/or dock facilities.

Installations outside of a 50 mile radius of the servicing dealer.

Local Prevailing Wage and/or Union Labor Rates.

Any additional charges shall be quoted by the dealer and approved by the buyer prior to performance of the work.

20. Terms and Conditions of Repair Parts

Not applicable

21. Service and Distribution Points

For service and distribution points nearest you, call (800) 851 1196.

22. Participating Dealers

Access Herman Miller web site for current list of participating dealers: www.HermanMiller.com/government.

23. Preventive Maintenance

Not applicable

24a. Special Attributes.

2018

For the 11th consecutive year, Herman Miller received a perfect score on the Corporate Equality Index and we were designated as Best Place to Work for LGBT equality. This report evaluates U.S. companies in terms of diversity, particularly their LGBT-related policies and practices.

Contract Information

continued

2017

Herman Miller was named the 2017 “Corporation of the Year” in the consumer products sector by the Michigan Minority Supplier Development Council (MMSDC).

Herman Miller has received a 2017 SEAL (Sustainability, Environmental Achievement and Leadership) Business Sustainability Award.

Herman Miller has earned the 4 Star Diversity Visionary Award. This award celebrates the diversity, equality, and inclusion work of Herman Miller. The award is presented at the annual Diversity Equity Inclusion Summit, held by the Grand Rapids Area Chamber of Commerce.

Herman Miller named one of the Best and Brightest in Wellness for the fifth year in a row.

Working Mother magazine has recognized Herman Miller as one of the 2017 Working Mother 100 Best Companies.

Herman Miller earned our tenth consecutive perfect score in Human Rights Campaign (HRC) Foundation’s 2017 Corporate Equality Index.

As one of the top-scoring companies in our industry for the thirteenth consecutive year, Herman Miller has qualified for inclusion in RobecoSAM’s 2017 Sustainability Yearbook and received the Bronze Class distinction for our excellent economic, environmental, and social sustainability performance.

Herman Miller has once again earned the WorldatWork Seal of Distinction, a unique standard of excellence in work-life effectiveness that shows we provide a distinct, mutually beneficial workplace experience.

2016

Herman Miller was recognized as the Business of the Year at the Annual Meeting of the West Michigan Environmental Action Council (WMEAC). This award goes to the business with the greatest depth and breadth of support, unwavering dedication to environmental action in West Michigan, and a strong corporate commitment to environmental advocacy.

The 101 Best and Brightest Sustainable Companies once again (fifth consecutive year) recognized Herman Miller as an organization in Michigan (and for the first time, in the nation) that exhibits leadership and innovation in its approach to sustainability.

Herman Miller has been recognized by the Michigan Minority Supplier Development Council (MMSDC), as a “Corporation of the Year”, and we also received a “2016 Excellence in Supplier Diversity Award” from the Great Lakes Women’s Business Council. Additionally, we are the only West Michigan company this year to receive an “Ambassadors Championing Excellence” Award from the MMSDC.

Plex Lounge Furniture from Herman Miller receives #MetropolisLikes award at NeoCon 2016.

Plex Lounge Furniture from Herman Miller receives Interior Design HiP Award for Workplace Seating/Lounge at NeoCon 2016.

Spot Stools from Herman Miller Collection receive Interior Design HiP Award for Hospitality Seating at NeoCon 2016.

Herman Miller has been named a 2020 Women on Boards Winning Company. Companies selected for this recognition are considered champions of board diversity as 20 percent or more of their board seats are occupied by women.

Herman Miller selected for inclusion in the 2016 RobecoSAM Sustainability Yearbook for twelfth consecutive year.

Herman Miller again earns the WorldatWork Work-Life 2016 Seal of Distinction. This award identifies organizations that focus on programs that promote work-life balance and overall well-being.

2015

Herman Miller earns ninth consecutive perfect score in Human Rights Campaign (HRC) Foundation’s 2016 Corporate Equality Index and we were designated as Best Place to Work for LGBT equality.

This is the fourth consecutive year that Herman Miller was named one of Michigan’s Best and Brightest Sustainable Companies.

Herman Miller has received the Best and Brightest in Wellness Award for the third year in a row. This program is an innovative initiative that recognizes and celebrates quality and excellence in health awareness.

Herman Miller received the Forest Stewardship Council (FSC) Leadership Award for longstanding commitment to manufacturing with wood sourced from responsibly managed forests, which reduces environmental impacts by protecting against deforestation and forest degradation.

Herman Miller accepted its second Excellence in Reusable Packaging Award from the Reusable Packaging Association.

Herman Miller has once again been recognized for its commitment to best-in-class economic, environmental, and societal sustainability, earning a spot on the prestigious Dow Jones Sustainability Index (DJSI) for the twelfth consecutive year. We are the only contract furniture company recognized globally for its corporate sustainability leadership.

Herman Miller selected for inclusion in the 2015 RobecoSAM Sustainability Yearbook; awarded Bronze Class distinction for excellent sustainability performance for the second consecutive year.

Contract Information

continued

Herman Miller received a Michigan Business Pollution Prevention (MBP₃) Certificate – a recognition given by the Michigan Department of Environmental Quality (MDEQ) to organizations committed to environmental stewardship, conservation, and sustainable operations. This basic partnership with the MDEQ, which we've maintained since 1998, makes us eligible for our Clean Corporate Citizen (CCC) status that began in 2004 and our Environmental Leader status, which we received for the first time this past year.

MedAssets named Herman Miller Healthcare as Platinum Suppliers. MedAssets, a large group purchasing organization, helps providers enhance operational and financial performance so they can sustainably serve the needs of their community.

Herman Miller honored with five of 20 spots for the Michigan Environmental Leaders Award by the Michigan Department of Environmental Quality for our outstanding, voluntary environmental stewardship.

Renew Sit-to-Stand tables recognized on Record Products 2014 list by Architectural Record.

Herman Miller was again awarded a perfect score in the 2015 Corporate Equality Index. This is the eighth consecutive year we received a perfect score.

2014

Herman Miller has received the Best and Brightest in Wellness Award for the second year in a row. This program is an innovative initiative that recognizes and celebrates quality and excellence in health awareness.

Herman Miller's Locale wins International Design Excellence Awards (IDEA) Gold in the Office & Productivity category.

Herman Miller achieves eleventh consecutive listing on Dow Jones Sustainability World Index, an international stock portfolio that evaluates the annual performance of the world's largest 2500 companies using economic, environmental, and social criteria, known as the "triple bottom line" of sustainability.

2013

Herman Miller achieves tenth consecutive listing on Dow Jones Sustainability World Index.

Herman Miller has received the Best and Brightest in Wellness Award. This program is an innovative initiative that recognizes and celebrates quality and excellence in health awareness.

Herman Miller Earns Perfect Score on the Corporate Equality Index. We are one of only 303 major U.S. businesses to receive a perfect score in 2013, an achievement we have now obtained seven years in a row.

Herman Miller is listed in Forbes Magazine inaugural "Platinum List" of America's 400 best managed, large companies.

For the second consecutive year, Herman Miller is honored as one of West Michigan's "101 Best and Brightest Sustainable Companies".

2012

Herman Miller accepted its first Excellence in Reusable Packaging Award from the Reusable Packaging Association.

Herman Miller is named "Corporation of the Year" in the commercial products sector by the Michigan Minority Supplier Development Council.

In July 2012 Herman Miller was inducted into the Made in the USA Hall of Fame. Herman Miller is one of only 20 companies across the nation to receive this distinction.

Herman Miller achieves ninth consecutive listing on Dow Jones Sustainability World Index.

Herman Miller is honored as one of West Michigan's 101 Best and Brightest Sustainable Companies.

The Sustainable Asset Management (SAM) group selected Herman Miller for inclusion in "The Sustainability Yearbook 2012" and has awarded Herman Miller both the "SAM Sector Leader" and "SAM Sector Mover" distinctions.

Herman Miller was named one of 16 Section Leaders on Climate Counts 2011-2012 Scorecard Report, making us the industry leader for Home and office Furnishings.

SGS International Certification Services, Inc., recognizes Herman Miller's manufacturing sites, Midwest Distribution Center, and Design Yard for initial certification to the OHSAS 18001 standard as well as re-certification to ISO 14001.

2011

Trust Across America, a company dedicated to unraveling the complexities of trustworthy business behavior, listed Herman Miller as one of their "Top Ten Most Trustworthy Companies in America 2011."

The U.S. Environmental Protection Agency (EPA) selected Herman Miller, as a WasteWise Gold Achievement—Climate Change winner.

Herman Miller achieves eighth consecutive listing on Dow Jones Sustainability World Index, an international stock portfolio that evaluates the annual performance of the world's largest 2500 companies using economic, environmental, and social criteria, known as the "triple bottom line" of sustainability.

The Michigan Minority Supplier Development Council (MMSDC) named Herman Miller as its "Corporation of the Year" in the commercial products sector. This was the fifth time Herman Miller has received this award since 2005.

Contract Information

continued

Herman Miller accepted its third Neighborhood Environmental Partners (NEP) award from the Michigan Department of Natural Resources and Environment.

Herman Miller receives the Reader's Choice award from TreeHugger's Best of Green: Design and Architecture category for the SAYL chair.

Herman Miller earns Citibank's Global Environmental Vendor of the Year award.

The SAYL chair from Herman Miller was dubbed the "Product Design of the Year" from the 2010 International Design Awards (IDA) jury.

Herman Miller Healthcare's Compass system was awarded a 2011 Medical Design Excellence Award (MDEA) for its research-based design and ability to be used in a variety of healing spaces, while simultaneously improving the overall delivery of healthcare.

The Sustainable Asset Management (SAM) Group selected Herman Miller for inclusion in the "Sustainability Yearbook 2011" and awarded us both the "SAM Sector Leader" and "SAM Sector Mover" distinctions.

Herman Miller has received the top rating for a fourth consecutive year in the Human Rights Campaign (HRC) Foundation's eighth annual Corporate Equality Index. The "Best Places to Work for LGBT Equality" distinction is awarded to businesses that scored 100% on the HRC Foundation's 2011 Corporate Equality Index.

Herman Miller again tops contract furniture industry in FORTUNE's "Most Admired" Companies survey. For the 23rd time in 25 years.

2010

The NASDAQ OMX CRD Global Sustainability Index (QCRD) has included Herman Miller among their top 100 companies in the world.

Herman Miller achieves seventh consecutive listing on Dow Jones Sustainability World Index, an international stock portfolio that evaluates the annual performance of the world's largest 2500 companies using economic, environmental, and social criteria, known as the "triple bottom line" of sustainability. Herman Miller is one of approximately 300 companies worldwide and the only contract office furniture manufacturer, selected for this index.

Herman Miller has been recognized by Fast Company magazine as one of its 2010 Most Innovative Companies and among the more select Innovation All-Stars.

The U.S. Environmental Protection Agency's Office of Resource Conservation and Recovery has selected Herman Miller to receive the 2010 WasteWise Gold Achievement Award for Green Purchasing.

The Michigan Department of Natural Resources and Environment (MDNRE) has recognized Herman Miller's West Michigan manufacturing sites and Midwest Distribution Center as continuing Clean Corporate Citizens.

Herman Miller makes the U.S. Environmental Protection Agency's (EPA) list of the top fifty users of renewable electricity, of more than 1,200 organizations participating in the Green Power Partnership. This is the second consecutive time Herman Miller was recognized. Herman Miller was the only furniture manufacturer on the list.

Herman Miller accepted its second Neighborhood Environmental Partners (NEP) award from the Michigan Department of Natural Resources and Environment.

For the 22nd time in 24 years, Herman Miller was awarded the No. 1 industry ranking in a survey among the executives and board members of peer companies and independent industry analysts, as published in FORTUNE magazine's annual "Most Admired" companies feature.

The Michigan Department of Environmental Quality (MDEQ) recognizes Herman Miller's GreenHouse as one of Michigan's top environmental performers with a Clean Corporate Citizen (C3) longevity award. This recognizes that the GreenHouse has maintained its C3 designation for the past five years.

For the third year in a row, Herman Miller makes FORTUNE magazine's "100 Best Companies to Work For" list. Herman Miller is one of only three Michigan-based companies to make the list.

24b. Section 508 Compliance

Not applicable

25. Data Universal Numbering System (DUNS): 00-601-2801

26. Registered in System for Award Management (www.SAM.gov) Database

27. Cancellation

Prior to production, no cancellation charge will apply. After production, only actual cost incurred that the contractor can demonstrate if items are sold after 3 months.

28. Restocking Charges

Agencies must notify the contractor for authorization prior to returning any items. The customer agency will be required to pay all packaging and return freight charges. A restocking fee of 50% for Systems Furniture and 35% for all other product lines will be charged for any returned items.

Herman Miller Miscellaneous Information:

Federal ID Number: 38-0837640

Commercial and Government Entity Code (CAGE): 40636

Data Universal Numbering System (DUNS) 00-601-2801

Commercial Entity Code (CEC): 00702290J

Introduction	page 2
Tu® Metal Storage	3
Pedestals	5
Pedestal Accessories	61
Lateral Files	69
Overfiles	83
File Tops	91
Lateral File Accessories	93
Storage Towers	100
Tower Accessories	124
Storage Cases	131
Bookcases	140
Keyless Locks	143
Indices	147
By Name	147
By Number	149
Appendices	
20-Day or Less/Assigned Lead-Time Order Information	
Keyed-Alike Information	
Customer's Own Material/Customer's Own Leather Order Information-Cushion Tops	
For the latest materials information, refer to the Materials pages on HermanMiller.com.	

Introduction

A Note on the Organization of This Book

There are a few signals that will help you understand the organization of this book. Once you know them, you should be able to find your way around easily.

Like a newspaper, this book is formatted with columns of text and illustrations that run vertically.

Information wraps from one column to the next and continues for as many pages as it needs to.

Black bars are clues.

A black bar at the top of a page signals the start of information about a product.

This information is divided into two sections, each signaled by a black bar. Product Information includes a description, additional notes, and dimensional drawings. Specification Information, which always begins at the top of a column, includes a series of steps. Each step represents a decision you need to make in order to complete your product number. Steps must be followed sequentially. The number of pages needed to complete information on a product varies; some will be complete in one page; others may fill three or four pages. Just continue going through the steps until you run into the next product, signaled by the black bar at the top of the page.

Black tabs running along the outside edge of the page help you locate what section you are in or what section you want to go to. You can thumb forwards or backwards to find a section; tabs and text appear on both sides of the page.

The additional pages in the back of the book include the appendices and indices. They are signaled by a long black bar running along the outside edge of the page.

The index is presented two ways.

The first index is in alphabetical order by product name. It can be helpful if you are new to the products and numbering scheme or if you are looking for a type of product, such as work chair or round table.

The second index is by product number. It lists, in alphanumeric order, the base product number, typically a five-digit number.

General Information

This book is effective April 2, 2018, subject to change without notice. Products may be purchased from authorized Herman Miller dealers who will quote prices upon request. For more information about our products and services or to see a list of dealers, visit www.HermanMiller.com.

All prices are list prices. Additional services, such as planning services, design, storage, and installation, are not included and must be added to these prices when the additional services are requested.

Illustrations, specifications, and prices are based on the latest information at the time of publication. The right is reserved to make changes at any time without notice in prices, fabrics, finishes, materials, specifications, and models, and also to discontinue models and finishes.

Dimensions shown in the drawings are engineering drawing dimensions rounded up to the nearest $\frac{1}{8}$ ". Product is shipped set up or knocked down. Products that include "Shipped knocked down" in the description require some assembly. If this statement does not appear in the description, the product is shipped assembled.

Service problems are normally handled by a Herman Miller authorized dealer. Where this cannot be accomplished on a local level, service problems should be referred to the Customer Care Representative for your region, Herman Miller, Inc., Zeeland, Michigan 49464.

20-Day or Less/Assigned Lead-Time Shipments

All products and options in this price book not designated by an Assigned Program icon  will ship in **20 business days or less** after being acknowledged by Herman Miller.

Products and options designated by an  are on the assigned lead-time program and may ship in 20 days, less than 20 days, or more than 20 days from order acknowledgement.

Metal Storage

Keyless Locks



Bar-Pull Freestanding Pedestal

LK10A.
LK10D.

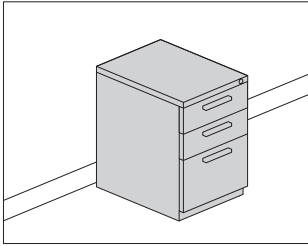

Product Information

Description

This freestanding pedestal fits below a hanging or freestanding work surface. It has a painted or veneer front, smooth-steel case, applied metal bar pulls, and 1" leveling glides. A counterweight is included. Actual pedestal depth is 19³/₈", 23¹/₄", or 27¹/₄". Standard-height pedestal is 26³/₈" high; raised-height pedestal is 27¹/₄" high. Raised-height configuration adds 7⁷/₈" to overall height to fill the space between the top of the pedestal and the underside of a surface. Box drawers are available with 3⁴/₄-extension or full-extension slides. File drawers have full-extension slides and hold letter-size front-to-back hanging files.

Notes

To add drawer divider, pencil tray, and file converters to drawer interiors, specify option (2M) or (3M).

For full extension slides on box drawers, specify option (SB).

Base on 2 drawers, raised height option (1) aligns with base on Tu® storage towers.

Pedestal will not fit below the following products:

- Action Office® table
 - Ethospace® round-end peninsula with access
- 24"-deep pedestal will not fit below the following products:
- 24"-deep Ethospace work surface with cable management trough
 - Action Office 60"-wide work surface

28"-deep pedestal will not fit below the following products:

- 30"-deep Ethospace work surface with cable management trough
- Action Office 60"-wide work surface

Grain direction is vertical for veneer-front pedestals.

Order optional accessories separately:

- Drawer divider (LG903.)
- File compressor (LG908)
- File converter (LG907)
- File drawer organizer (LG901)
- Pedestal stationery divider (LG905)
- Utility tray (LG906)
- Storage organizer (LG910)

Storage organizer includes a hanging file holder, utility tray (pencil tray) and 2 containers. Storage organizer frame color matches drawer interior; file holder and containers are g1 white; utility tray is black.

For keyed-alike locks, order lock plugs separately. See Keyed-Alike Information in Appendices.

Dimensions

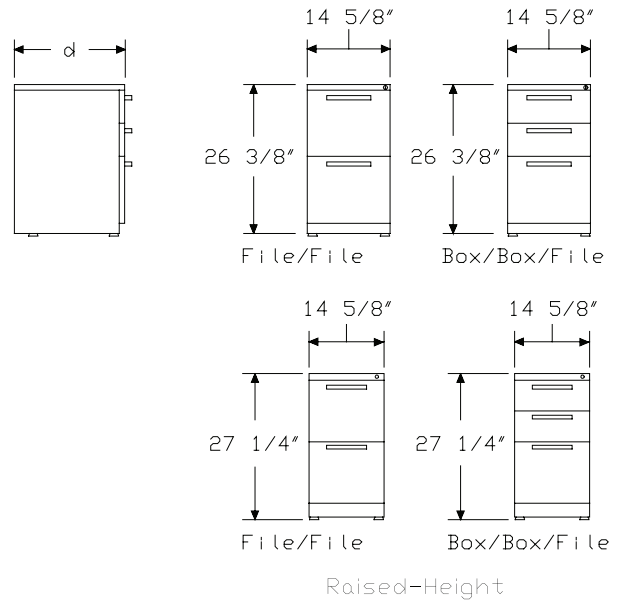

Bar-Pull Freestanding Pedestal

continued

Tu® Metal Storage

Specification Information

Step 1.

LK10

Step 2. Front Material

- D.** painted metal front
- A.** veneer front A

Step 3. Depth

- 20** 20" deep
- 24** 24" deep
- 28** 28" deep

Step 4. Configuration

- BBF** box/box/file
- FF** file/file

Prices for Steps 1-4.

	BBF	FF
LK10D. 20	\$652	670
24	\$690	707
28	\$753	770
LK10A. 20	\$883	902
24	\$920	939
28	\$987	1004

Step 5. Slides

For box/box/file (BBF)

- SR** ¾-extension roller slides on box drawer, full-extension ball bearing on file drawer +\$0
- SB** full-extension ball-bearing +\$50

For file/file (FF)

- SB** full-extension ball-bearing +\$0

Step 6. Paint/Steel Type

- SS** smooth paint on smooth steel +\$0
- XS** textured paint on smooth steel +\$0

Step 7. Surface Finish

For smooth paint on smooth steel (SS)

- 98** studio white +\$0
- 8Q** folkstone grey +\$0
- BU** black umber +\$0
- HF** inner tone light +\$0
- LT** light tone +\$0
- LU** soft white +\$0
- MT** medium tone +\$0
- SG** slate grey +\$0
- WL** sandstone +\$0
- CN** metallic champagne +\$40
- EH** metallic bronze +\$40
- MS** metallic silver +\$40

Sand Texture Paint

For textured paint on smooth steel (XS)

- 98** studio white +\$0

Bright Sand Texture Paint

For textured paint on smooth steel (XS)

- 91** white +\$0
- CL** cool grey neutral +\$0
- G1** graphite +\$0
- WN** warm grey neutral +\$0

Step 8. Front Finish

For veneer front (A.)

Recut Veneer

- RA** light ash A +\$0
- RK** mahogany dark A +\$0
- RM** mahogany A +\$0

Wood Veneer

- 2U** light brown walnut A +\$107
- 40** dark brown walnut A +\$107
- ED** aged cherry A +\$107
- EK** medium red walnut A +\$107
- EW** medium matte walnut A +\$107
- ET** clear on ash A +\$107
- EV** walnut on ash A +\$107
- UL** natural maple A +\$107
- UX** walnut on cherry A +\$107

Bar-Pull Freestanding Pedestal

continued

Step 9. Lock		
KA	keyed alike	+\$0
KC	keyed differently, chrome	+\$0
KD	keyed differently, black	+\$0

Step 10. Pull Finish		
8Q	folkstone grey	+\$0
91	white	+\$0
98	studio white	+\$0
G1	graphite <input type="checkbox"/>	+\$0
WL	sandstone <input type="checkbox"/>	+\$0
CN	metallic champagne <input type="checkbox"/>	+\$0
MS	metallic silver	+\$0
79	green apple <input type="checkbox"/>	+\$15
MY3	yellow oxide <input type="checkbox"/>	+\$15
RO	red <input type="checkbox"/>	+\$15
TRQ	turquoise <input type="checkbox"/>	+\$15

Step 11. Base Height		
1F	standard height	+\$0
2F	raised height	+\$0

Step 12. Drawer Interior		
<i>For box/box/file (BBF)</i>		
NN	none	+\$0
2M	drawer divider in box drawers, 2 file converters in file drawer	+\$25
3M	drawer divider in one box drawer, pencil tray in one box drawer, 2 file converters in file drawer	+\$25
C51	storage organizer including hanging file holder bin, utility tray and two containers <input type="checkbox"/>	+\$120

<i>For file/file (FF)</i>		
NN	none	+\$0
1M	2 file converters in each file drawer	+\$25
C51	storage organizer including hanging file holder bin, utility tray and two containers <input type="checkbox"/>	+\$120

Arc Pull Freestanding Pedestal

LQ10A.
LQ10D.

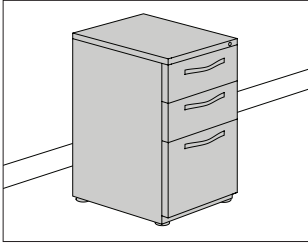

Tu® Metal Storage

Product Information

Description

This freestanding pedestal fits below a hanging or freestanding work surface. It has a painted or veneer front, smooth-steel case, applied metal arc pulls, and 1" leveling glides. A counterweight is included. Actual pedestal depth is 19³/₈", 23³/₄", or 27³/₄". Standard-height pedestal is 26³/₈" high; raised-height pedestal is 27¹/₄" high. Raised-height configuration adds 7/₈" to overall height to fill the space between the top of the pedestal and the underside of a surface. Box drawers are available with 3/₄-extension or full-extension slides. File drawers have full-extension slides and hold letter-size front-to-back hanging files.

Notes

Pull design conforms to guidelines of Americans with Disabilities Act (ADA).
To add drawer divider, pencil tray, file converters and storage organizer to drawer interiors, specify option (1M), (2M), (3M) or (C51).
For full extension slides on box drawers, specify option (SB).
Base on 2 drawers, raised height option (1) aligns with base on Tu® storage towers.
Pedestal will not fit below the following products:

- Action Office® table
- Ethospace® round-end peninsula with access

24"-deep pedestal will not fit below the following products:

- 24"-deep Ethospace work surface with cable management trough
- Action Office 60"-wide work surface

28"-deep pedestal will not fit below the following products:

- 30"-deep Ethospace work surface with cable management trough
- Action Office 60"-wide work surface

Grain direction is vertical for veneer-front pedestals.
Order optional accessories separately:

- Drawer divider (LG903.)
- File compressor (LG908)
- File converter (LG907)
- File drawer organizer (LG901)
- Pedestal stationery divider (LG905)
- Utility tray (LG906)
- Storage organizer (LG910)

Storage organizer includes a hanging file holder, utility tray (pencil tray) and 2 containers. The storage organizer frame color matches the drawer interior; file holder and containers are 91 white; utility tray is black.
For keyed-alike locks, order lock plugs separately. See Keyed-Alike Information in Appendices.

Dimensions

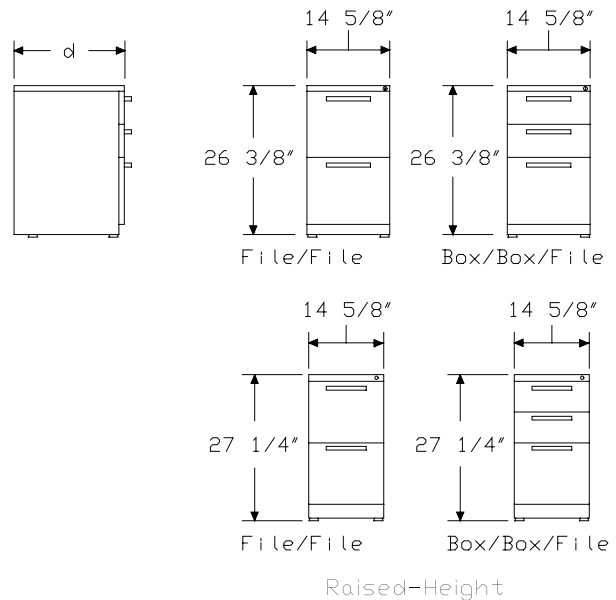

Arc Pull Freestanding Pedestal

continued

Specification Information

Step 1.

LQ10

Step 2. Front Material

- D.** painted metal front
- A.** veneer front A

Step 3. Depth

- 20** 20" deep
- 24** 24" deep
- 28** 28" deep

Step 4. Configuration

- BBF** box/box/file
- FF** file/file

Prices for Steps 1-4.

	BBF	FF
LQ10D. 20	\$652	670
24	\$690	707
28	\$753	770
LQ10A. 20	\$883	902
24	\$920	939
28	\$987	1004

Step 5. Slides

For box/box/file (BBF)

- SR** ¾-extension roller slides on box drawer, full-extension ball bearing on file drawer +\$0
- SB** full-extension ball-bearing +\$50

For file/file (FF)

- SB** full-extension ball-bearing +\$0

Step 6. Paint/Steel Type

- SS** smooth paint on smooth steel +\$0
- XS** textured paint on smooth steel +\$0

Step 7. Surface Finish

For smooth paint on smooth steel (SS)

- 8Q** folkstone grey +\$0
- 98** studio white +\$0
- BU** black umber +\$0
- CN** metallic champagne +\$40
- EH** metallic bronze +\$40
- HF** inner tone light +\$0
- LT** light tone +\$0
- LU** soft white +\$0
- MS** metallic silver +\$40
- MT** medium tone +\$0
- SG** slate grey +\$0
- WL** sandstone +\$0

Sand Texture Paint

For textured paint on smooth steel (XS)

- 98** studio white +\$0

Bright Sand Texture Paint

For textured paint on smooth steel (XS)

- 91** white +\$0
- CL** cool grey neutral +\$0
- G1** graphite +\$0
- WN** warm grey neutral +\$0

Step 8. Front Finish

For veneer front (A.)

Recut Veneer

- RA** light ash A +\$0
- RK** mahogany dark A +\$0
- RM** mahogany A +\$0

Wood Veneer

- 2U** light brown walnut A +\$107
- 40** dark brown walnut A +\$107
- ED** aged cherry A +\$107
- EK** medium red walnut A +\$107
- EW** medium matte walnut A +\$107
- ET** clear on ash A +\$107
- EU** oak on ash A +\$107
- EV** walnut on ash A +\$107
- UL** natural maple A +\$107
- UX** walnut on cherry A +\$107

Arc Pull Freestanding Pedestal

continued

Tu® Metal Storage

Step 9. Lock

KA	keyed alike	+\$0
KC	keyed differently, chrome	+\$0
KD	keyed differently, black	+\$0

Step 10. Pull Finish

NH	brushed nickel	+\$0
NK	black nickel	+\$0

Step 11. Base Height

1F	standard height	+\$0
2F	raised height	+\$0

Step 12. Drawer Interior

For 20" deep (20) or 24" deep (24) with box/box/file (BBF)

NN	none	+\$0
2M	drawer divider in box drawers, 2 file converters in file drawer	+\$25
3M	drawer divider in one box drawer, pencil tray in one box drawer, 2 file converters in file drawer	+\$25
C51	storage organizer including hanging file holder bin, utility tray and two containers <input type="checkbox"/>	+\$120

For 28" deep (28) with box/box/file (BBF)

NN	none	+\$0
2M	drawer divider in box drawers, 2 file converters in file drawer	+\$25
3M	drawer divider in one box drawer, pencil tray in one box drawer, 2 file converters in file drawer	+\$25

For 20" deep (20) or 24" deep (24) with file/file (FF)

NN	none	+\$0
1M	2 file converters in each file drawer	+\$25
C51	storage organizer including hanging file holder bin, utility tray and two containers <input type="checkbox"/>	+\$120

For 28" deep (28) with file/file (FF)

NN	none	+\$0
1M	2 file converters in each file drawer	+\$25

W-Pull Freestanding Pedestal

LW100.

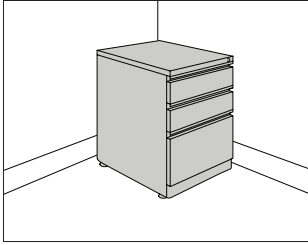

Product Information

Description

This freestanding pedestal fits below a hanging or freestanding work surface. It has a smooth-steel case, full-width pulls, and 1" leveling glides. Counterweight is included.

Actual pedestal depth is 19³/₈", 23¹/₄", or 27³/₄". Standard-height pedestal is 26³/₈" high; raised-height pedestal is 27¹/₄" high. Raised-height configuration adds 7⁷/₈" to overall height to fill the space between the top of the file and the underside of a surface.

Drawers are available with full-extension or 3/4-extension slides. A drawer divider, utility tray or storage organizer is optional for box drawers. File drawers hold letter-size front-to-back hanging files. File converters are optional for letter-, legal-, and A4-size side-to-side hanging files.

Notes

Base on 2 drawers, raised height option (1) aligns with base on Tu® storage towers.

Pedestal will not fit below the following products:

- Action Office® table
 - Ethospace® round-end peninsula with access
- 24"-deep pedestal will not fit below the following products:
- 24"-deep Ethospace work surface with cable management trough
 - Action Office 60"-wide work surface

28"-deep pedestal will not fit below the following products:

- 30"-deep Ethospace work surface with cable management trough
- Action Office 60"-wide work surface

Order optional accessories separately:

- Drawer divider (LG903.)
- File compressor (LG908)
- File converter (LG907)
- File drawer organizer (LG901)
- Pedestal stationery divider (LG905)
- Utility tray (LG906)
- Storage organizer (LG910)

Storage organizer includes a hanging file holder, utility tray (pencil tray) and 2 containers. The storage organizer frame color matches the drawer interior; file holder and containers are 91 white; utility tray is black.

For keyed-alike locks, order lock plugs separately. See Keyed-Alike Information in Appendices.

Dimensions

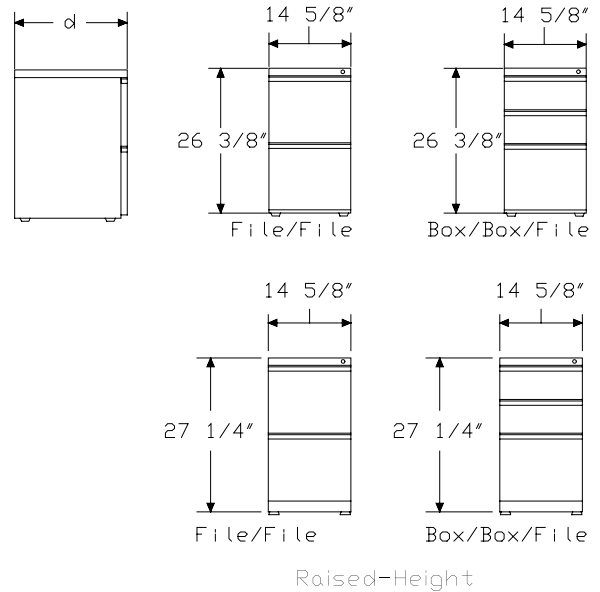

W-Pull Freestanding Pedestal

continued

Tu® Metal Storage

Specification Information

Step 1.

LW100.

Step 2. Depth

20	20" deep
24	24" deep
28	28" deep

Step 3. Configuration

BBF	box/box/file
FF	file/file

Prices for Steps 1-3.

	BBF	FF
LW100.20	\$562	515
24	\$575	530
28	\$646	596

Step 4. Slides

For box/box/file (BBF)

SR	3/4"-extension roller slides on box drawer, full-extension ball bearing on file drawer	+\$0
SB	full-extension ball-bearing	+\$50

For file/file (FF)

SB	full-extension ball-bearing	+\$0
-----------	-----------------------------	------

Step 5. Paint/Steel Type

SS	smooth paint on smooth steel	+\$0
XS	textured paint on smooth steel	+\$0

Step 6. Surface Finish

For smooth paint on smooth steel (SS)

8Q	folkstone grey	+\$0
98	studio white	+\$0
BU	black umber	+\$0
CN	metallic champagne	+\$40
EH	metallic bronze	+\$40
HF	inner tone light	+\$0
LT	light tone	+\$0
LU	soft white	+\$0
MS	metallic silver	+\$40
MT	medium tone	+\$0
SG	slate grey	+\$0
WL	sandstone	+\$0

Sand Texture Paint

For textured paint on smooth steel (XS)

98	studio white	+\$0
-----------	--------------	------

Bright Sand Texture Paint

For textured paint on smooth steel (XS)

91	white	+\$0
CL	cool grey neutral	+\$0
G1	graphite	+\$0
WN	warm grey neutral	+\$0

Step 7. Lock

KA	keyed alike	+\$0
KC	keyed differently, chrome	+\$0
KD	keyed differently, black	+\$0

Step 8. Base Height

1F	standard height	+\$0
2F	raised height	+\$0

Step 9. Drawer Interior

For 20" deep (20) or 24" deep (24) with box/box/file (BBF)

NN	none	+\$0
2M	drawer divider in box drawers, 2 file converters in file drawer	+\$25
3M	drawer divider in one box drawer, pencil tray in one box drawer, 2 file converters in file drawer	+\$25
C51	storage organizer including hanging file holder bin, utility tray and two containers A	+\$120

W-Pull Freestanding Pedestal

continued

For 28" deep (28) with box/box/file (BBF)

NN	none	+\$0
2M	drawer divider in box drawers, 2 file converters in file drawer	+\$25
3M	drawer divider in one box drawer, pencil tray in one box drawer, 2 file converters in file drawer	+\$25

For 20" deep (20) or 24" deep (24) with file/file (FF)

NN	none	+\$0
1M	2 file converters in each file drawer	+\$25
C51	storage organizer including hanging file holder bin, utility tray and two containers A	+\$120

For 28" deep (28) with file/file (FF)

NN	none	+\$0
1M	2 file converters in each file drawer	+\$25

V-Pull Freestanding Pedestal

LV100.

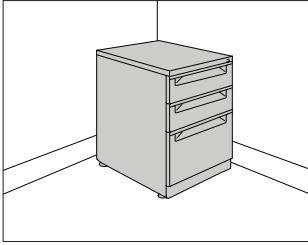

Tu® Metal Storage

Product Information

Description

This freestanding pedestal fits below a hanging or freestanding work surface. It has a smooth-steel case, full-width recessed pulls, and 1" leveling glides. Counterweight is included.

Actual pedestal depth is 19³/₈", 23³/₄", or 27³/₄". Standard-height pedestal is 26³/₈" high; raised-height pedestal is 27¹/₄" high. Raised-height configuration adds 7/₈" to overall height to fill the space between the top of the pedestal and the underside of a surface.

Drawers are available with full-extension or 3/₄-extension slides. A drawer divider, utility tray or storage organizer is optional for box drawers. File drawers hold letter-size front-to-back hanging files. File converters are optional for letter-, legal-, and A4-size side-to-side hanging files.

Notes

Base on 2 drawers, raised height option (1) aligns with base on Tu® storage towers.

Pedestal will not fit below the following products:

- Action Office® table
 - Ethospace® round-end peninsula with access
- 24"-deep pedestal will not fit below the following products:
- 24"-deep Ethospace work surface with cable management trough
 - Action Office 60"-wide work surface

28"-deep pedestal will not fit below the following products:

- 30"-deep Ethospace work surface with cable management trough
- Action Office 60"-wide work surface

Order optional accessories separately:

- Drawer divider (LG903.)
- File compressor (LG908)
- File converter (LG907)
- File drawer organizer (LG901)
- Pedestal stationery divider (LG905)
- Utility tray (LG906)
- Storage organizer (LG910)

Storage organizer includes a hanging file holder, utility tray (pencil tray) and 2 containers. The storage organizer frame color matches the drawer interior; file holder and containers are 91 white; utility tray is black.

For keyed-alike locks, order lock plugs separately. See Keyed-Alike Information in Appendices.

Dimensions

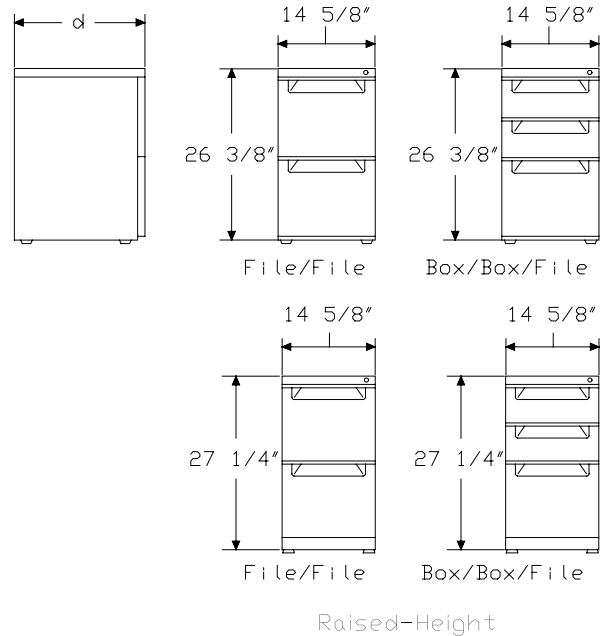

V-Pull Freestanding Pedestal

continued

Specification Information

Step 1.

LV100.

Step 2. Depth

20	20" deep
24	24" deep
28	28" deep

Step 3. Configuration

BBF	box/box/file
FF	file/file

Prices for Steps 1-3.

	BBF	FF
LV100. 20	\$577	532
24	\$595	545
28	\$666	611

Step 4. Slides

For box/box/file (BBF)

SR	¾-extension roller slides on box drawer, full-extension ball bearing on file drawer	+\$0
SB	full-extension ball-bearing	+\$50

For file/file (FF)

SB	full-extension ball-bearing	+\$0
-----------	-----------------------------	------

Step 5. Paint/Steel Type

SS	smooth paint on smooth steel	+\$0
XS	textured paint on smooth steel	+\$0

Step 6. Surface Finish

For smooth paint on smooth steel (SS)

8Q	folkstone grey	+\$0
98	studio white	+\$0
BU	black umber	+\$0
CN	metallic champagne	+\$40
EH	metallic bronze	+\$40
HF	inner tone light	+\$0
LT	light tone	+\$0
LU	soft white	+\$0
MS	metallic silver	+\$40
MT	medium tone	+\$0
SG	slate grey	+\$0
WL	sandstone	+\$0

Sand Texture Paint

For textured paint on smooth steel (XS)

98	studio white	+\$0
-----------	--------------	------

Bright Sand Texture Paint

For textured paint on smooth steel (XS)

91	white	+\$0
CL	cool grey neutral	+\$0
G1	graphite	+\$0
WN	warm grey neutral	+\$0

Step 7. Lock

KA	keyed alike	+\$0
KC	keyed differently, chrome	+\$0
KD	keyed differently, black	+\$0

Step 8. Base Height

1F	standard height	+\$0
2F	raised height	+\$0

Step 9. Drawer Interior

For 20" deep (20) or 24" deep (24) with box/box/file (BBF)

NN	none	+\$0
2M	drawer divider in box drawers, 2 file converters in file drawer	+\$25
3M	drawer divider in one box drawer, pencil tray in one box drawer, 2 file converters in file drawer	+\$25
C51	storage organizer including hanging file holder bin, utility tray and two containers A	+\$120

V-Pull Freestanding Pedestal

continued

Tu® Metal Storage

For 28" deep (28) with box/box/file (BBF)

NN	none	+\$0
2M	drawer divider in box drawers, 2 file converters in file drawer	+\$25
3M	drawer divider in one box drawer, pencil tray in one box drawer, 2 file converters in file drawer	+\$25

For 20" deep (20) or 24" deep (24) with file/file (FF)

NN	none	+\$0
1M	2 file converters in each file drawer	+\$25
C51	storage organizer including hanging file holder bin, utility tray and two containers A	+\$120

For 28" deep (28) with file/file (FF)

NN	none	+\$0
1M	2 file converters in each file drawer	+\$25

Bar Pull Mobile Pedestal

LK11A.
LK11D.

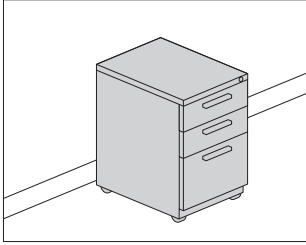

Product Information

Description

This mobile pedestal fits below a hanging or freestanding work surface. It has a painted or veneer front, smooth-steel case, applied metal bar pulls, and black rubber casters. Pedestal can be specified with or without a hand grip. Counterweight is included.

Actual pedestal depth is 19³/₈" or 23¹/₄".

Box drawers are available with 3/4"-extension or full-extension slides.

File drawers have full-extension slides and hold letter-size front-to-back hanging files.

Notes

To add drawer divider, pencil tray, and file converters to drawer interiors, specify option (2M) or (3M).

For full extension slides on box drawers, specify option (SB).

24"-deep pedestal will not fit below the following products:

- 24"-deep Ethospace® work surface with cable management trough
- Action Office® 60"-wide work surface

Grain direction is vertical for veneer-front pedestals.

Order optional accessories separately:

- Drawer divider (LG903.)
- File compressor (LG908)
- File converter (LG907)
- File drawer organizer (LG901)
- Pedestal stationery divider (LG905)
- Utility tray (LG906)
- Storage organizer (LG910)

Storage organizer includes a hanging file holder, utility tray (pencil tray) and 2 containers. Storage organizer frame color matches drawer interior; file holder and containers are 91 white; utility tray is black.

For keyed-alike locks, order lock plugs separately. See Keyed-Alike Information in Appendices.

Dimensions

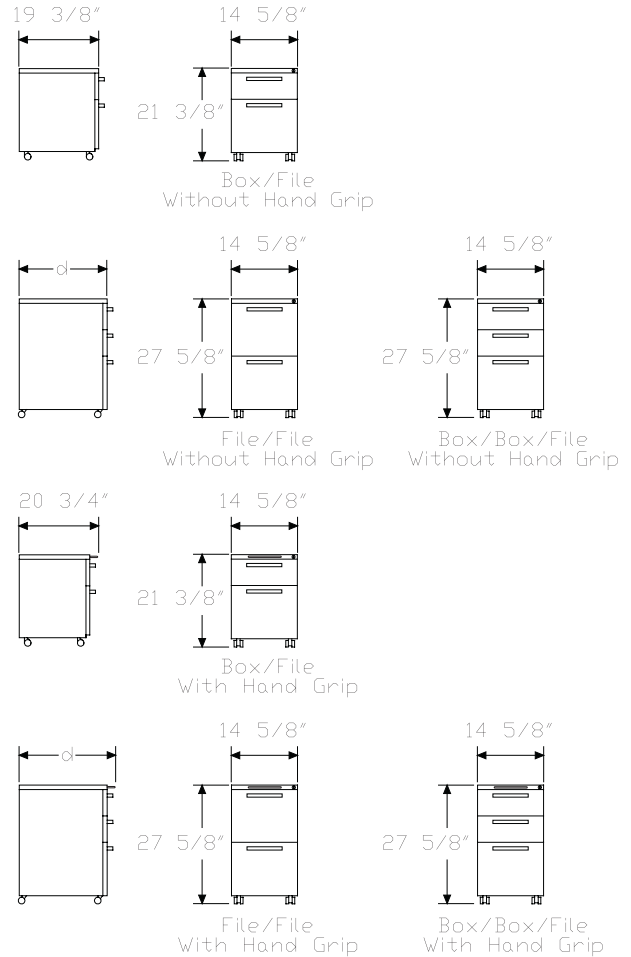

Specification Information

Step 1.
LK11

Step 2. Front Material
D. painted metal front
A. veneer front

Step 3. Depth
20 20" deep
24 24" deep

Step 4. Configuration

For 20" deep (20)
BBF box/box/file
BF box/file
FF file/file

For 24" deep (24)
BBF box/box/file
FF file/file

Prices for Steps 1-4.

	BBF	BF	FF
LK11D. 20	\$717	618	679
24	\$760	—	713
LK11A. 20	\$949	850	912
24	\$992	—	945

Step 5. Slides

For box/box/file (BBF)
SR 3/4-extension roller slides on box drawer, full-extension ball bearing on file drawer +\$0
SB full-extension ball-bearing +\$50

For box/file (BF)
SR 3/4-extension roller slides on box drawer, full-extension ball bearing on file drawer +\$0
SB full-extension ball-bearing +\$25

For file/file (FF)
SB full-extension ball-bearing +\$0

Step 6. Paint/Steel Type
SS smooth paint on smooth steel +\$0
XS textured paint on smooth steel +\$0

Step 7. Surface Finish

For smooth paint on smooth steel (SS)
98 studio white +\$0
8Q folkstone grey +\$0
BU black amber +\$0
HF inner tone light +\$0
LT light tone +\$0
LU soft white +\$0
MT medium tone +\$0
SG slate grey +\$0
WL sandstone +\$0
CN metallic champagne +\$40
EH metallic bronze +\$40
MS metallic silver +\$40

Sand Texture Paint
For textured paint on smooth steel (XS)
98 studio white +\$0

Bright Sand Texture Paint
For textured paint on smooth steel (XS)
91 white +\$0
CL cool grey neutral +\$0
G1 graphite +\$0
WN warm grey neutral +\$0

Step 8. Front Finish
For veneer front (A.)

Recut Veneer
RA light ash +\$0
RK mahogany dark +\$0
RM mahogany +\$0

Bar Pull Mobile Pedestal *continued*

Wood Veneer		
2U	light brown walnut <input type="checkbox"/>	+\$107
40	dark brown walnut <input type="checkbox"/>	+\$107
ED	aged cherry <input type="checkbox"/>	+\$107
EK	medium red walnut <input type="checkbox"/>	+\$107
EW	medium matte walnut <input type="checkbox"/>	+\$107
ET	clear on ash <input type="checkbox"/>	+\$107
EV	walnut on ash <input type="checkbox"/>	+\$107
UL	natural maple <input type="checkbox"/>	+\$107
UX	walnut on cherry <input type="checkbox"/>	+\$107

Step 9. Lock		
KA	keyed alike	+\$0
KC	keyed differently, chrome	+\$0
KD	keyed differently, black	+\$0

Step 10. Pull Finish		
8Q	folkstone grey	+\$0
91	white	+\$0
98	studio white	+\$0
G1	graphite <input type="checkbox"/>	+\$0
WL	sandstone <input type="checkbox"/>	+\$0
CN	metallic champagne <input type="checkbox"/>	+\$0
MS	metallic silver	+\$0
79	green apple <input type="checkbox"/>	+\$15
MY3	yellow oxide <input type="checkbox"/>	+\$15
RO	red <input type="checkbox"/>	+\$15
TRQ	turquoise <input type="checkbox"/>	+\$15

Step 11. Drawer Interior

For box/box/file (BBF)		
NN	none	+\$0
2M	drawer divider in box drawers, 2 file converters in file drawer	+\$25
3M	drawer divider in one box drawer, pencil tray in one box drawer, 2 file converters in file drawer	+\$25
C51	storage organizer including hanging file holder bin, utility tray and two containers <input type="checkbox"/>	+\$120

For box/file (BF)		
NN	none	+\$0
4M	drawer divider in box drawer, 2 file converters in file drawer	+\$20
5M	pencil tray in box drawer, 2 file converters in file drawer	+\$20
C51	storage organizer including hanging file holder bin, utility tray and two containers <input type="checkbox"/>	+\$120

For file/file (FF)		
NN	none	+\$0
1M	2 file converters in each file drawer	+\$25
C51	storage organizer including hanging file holder bin, utility tray and two containers <input type="checkbox"/>	+\$120

Step 12. Handle		
HN	no hand grip	+\$0
H1	hand grip only	+\$48

Arc Pull Mobile Pedestal

LQ11A.
LQ11D.

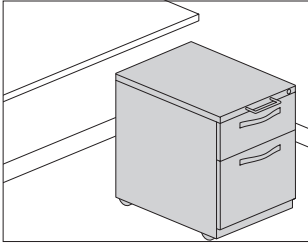

Tu® Metal Storage

Product Information

Description

This mobile pedestal fits below a hanging or freestanding work surface. It has a painted or veneer front, smooth-steel case, applied metal arc pulls, and black rubber casters. Pedestal can be specified with or without a hand grip. Counterweight is included.

Actual pedestal depth is 19³/₈" or 23¹/₄".

Box drawers are available with 3/4"-extension or full-extension slides.

File drawers have full-extension slides and hold letter-size front-to-back hanging files.

Notes

Pull design conforms to guidelines of Americans with Disabilities Act (ADA).

To add drawer divider, pencil tray, file converters and storage organizer to drawer interiors, specify option (1M), (2M), (3M), (4M), (5M) or (C51). For full extension slides on box drawers, specify option (SB).

24"-deep pedestal will not fit below the following products:

- 24"-deep Ethospace® work surface with cable management trough
- Action Office® 60"-wide work surface

Accepts Tu® add-on cushion top (LG890).

Grain direction is vertical for veneer-front pedestals.

Order optional accessories separately:

- Drawer divider (LG903.)
- File compressor (LG908)
- File converter (LG907)
- File drawer organizer (LG901)
- Pedestal stationery divider (LG905)
- Utility tray (LG906)
- Storage organizer (LG910)

Storage organizer includes a hanging file holder, utility tray (pencil tray) and 2 containers. The storage organizer frame color matches the drawer interior; file holder and containers are 91 white; utility tray is black.

For keyed-alike locks, order lock plugs separately. See Keyed-Alike Information in Appendices.

Dimensions

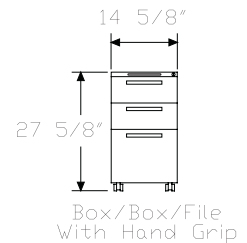
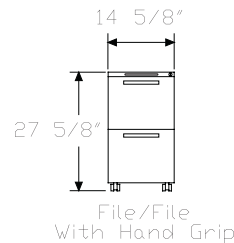
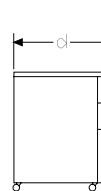
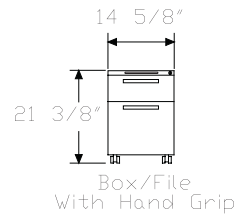
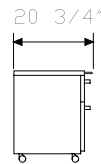
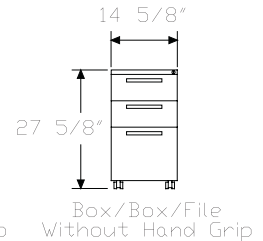
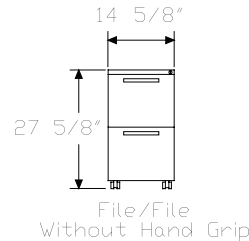
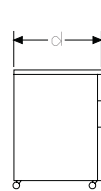
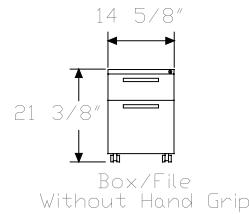
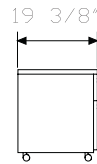

Specification Information

Step 1.
LQ11

Step 2. Front Material

- D.** painted metal front
- A.** veneer front A

Step 3. Depth

- 20** 20" deep
- 24** 24" deep

Step 4. Configuration

For 20" deep (20)

- BBF** box/box/file
- BF** box/file
- FF** file/file

For 24" deep (24)

- BBF** box/box/file
- FF** file/file

Prices for Steps 1-4.

	BBF	BF	FF
LQ11D. 20	\$717	618	679
24	\$760	—	713
LQ11A. 20	\$949	850	912
24	\$992	—	945

Step 5. Slides

For box/box/file (BBF)

- SR** ¾-extension roller slides on box drawer, full-extension ball bearing on file drawer +\$0
- SB** full-extension ball-bearing +\$50

For box/file (BF)

- SR** ¾-extension roller slides on box drawer, full-extension ball bearing on file drawer +\$0
- SB** full-extension ball-bearing +\$25

For file/file (FF)

- SB** full-extension ball-bearing +\$0

Step 6. Paint/Steel Type

- SS** smooth paint on smooth steel +\$0
- XS** textured paint on smooth steel +\$0

Step 7. Surface Finish

For smooth paint on smooth steel (SS)

- 8Q** folkstone grey +\$0
- 98** studio white +\$0
- BU** black umber +\$0
- CN** metallic champagne +\$40
- EH** metallic bronze +\$40
- HF** inner tone light +\$0
- LT** light tone +\$0
- LU** soft white +\$0
- MS** metallic silver +\$40
- MT** medium tone +\$0
- SG** slate grey +\$0
- WL** sandstone +\$0

Sand Texture Paint

For textured paint on smooth steel (XS)

- 98** studio white +\$0

Bright Sand Texture Paint

For textured paint on smooth steel (XS)

- 91** white +\$0
- CL** cool grey neutral +\$0
- G1** graphite +\$0
- WN** warm grey neutral +\$0

Step 8. Front Finish

For veneer front (A.)

Recut Veneer

- RA** light ash A +\$0
- RK** mahogany dark A +\$0
- RM** mahogany A +\$0

Arc Pull Mobile Pedestal *continued*

Tu® Metal Storage

Wood Veneer		
2U	light brown walnut <input type="checkbox"/> A	+\$107
40	dark brown walnut <input type="checkbox"/> A	+\$107
ED	aged cherry <input type="checkbox"/> A	+\$107
EK	medium red walnut <input type="checkbox"/> A	+\$107
EW	medium matte walnut <input type="checkbox"/> A	+\$107
ET	clear on ash <input type="checkbox"/> A	+\$107
EU	oak on ash <input type="checkbox"/> A	+\$107
EV	walnut on ash <input type="checkbox"/> A	+\$107
UL	natural maple <input type="checkbox"/> A	+\$107
UX	walnut on cherry <input type="checkbox"/> A	+\$107

Step 9. Lock		
KA	keyed alike	+\$0
KC	keyed differently, chrome	+\$0
KD	keyed differently, black	+\$0

Step 10. Pull Finish		
NH	brushed nickel	+\$0
NK	black nickel	+\$0

Step 11. Drawer Interior

For box/box/file (BBF)		
NN	none	+\$0
2M	drawer divider in box drawers, 2 file converters in file drawer	+\$25
3M	drawer divider in one box drawer, pencil tray in one box drawer, 2 file converters in file drawer	+\$25
C51	storage organizer including hanging file holder bin, utility tray and two containers <input type="checkbox"/> A	+\$120

For box/file (BF)		
NN	none	+\$0
4M	drawer divider in box drawer, 2 file converters in file drawer	+\$20
5M	pencil tray in box drawer, 2 file converters in file drawer	+\$20
C51	storage organizer including hanging file holder bin, utility tray and two containers <input type="checkbox"/> A	+\$120

For file/file (FF)		
NN	none	+\$0
1M	2 file converters in each file drawer	+\$25
C51	storage organizer including hanging file holder bin, utility tray and two containers <input type="checkbox"/> A	+\$120

Step 12. Handle		
HN	no hand grip	+\$0
H1	hand grip only	+\$48

W-Pull Mobile Pedestal

LW110.

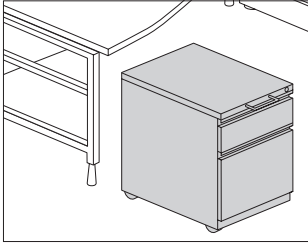

Product Information

Description

This mobile pedestal fits below a hanging or freestanding work surface. It has a smooth-steel case, full-width pulls, and black amber casters. Pedestal can be specified with or without a hand grip. Counterweight is included.

Actual pedestal depth is 19^{3/8}" or 23^{1/4}".

Drawers are available with full-extension or 3/4-extension slides. A drawer divider, utility tray or storage organizer is optional for box drawers. File drawers hold letter-size front-to-back hanging files. File converters are optional for letter-, legal-, and A4-size side-to-side hanging files.

Notes

24"-deep pedestal will not fit below the following products:

- 24"-deep Ethospace® work surface with cable management trough
- Action Office® 60"-wide work surface

Accepts Tu® add-on cushion top (LG890).

Order optional accessories separately:

- Drawer divider (LG903.)
- File compressor (LG908)
- File converter (LG907)
- File drawer organizer (LG901)
- Pedestal stationery divider (LG905)
- Utility tray (LG906)
- Storage organizer (LG910)

Storage organizer includes a hanging file holder, utility tray (pencil tray) and 2 containers. The storage organizer frame color matches the drawer interior; file holder and containers are 91 white; utility tray is black.

For keyed-alike locks, order lock plugs separately. See Keyed-Alike Information in Appendices.

Dimensions

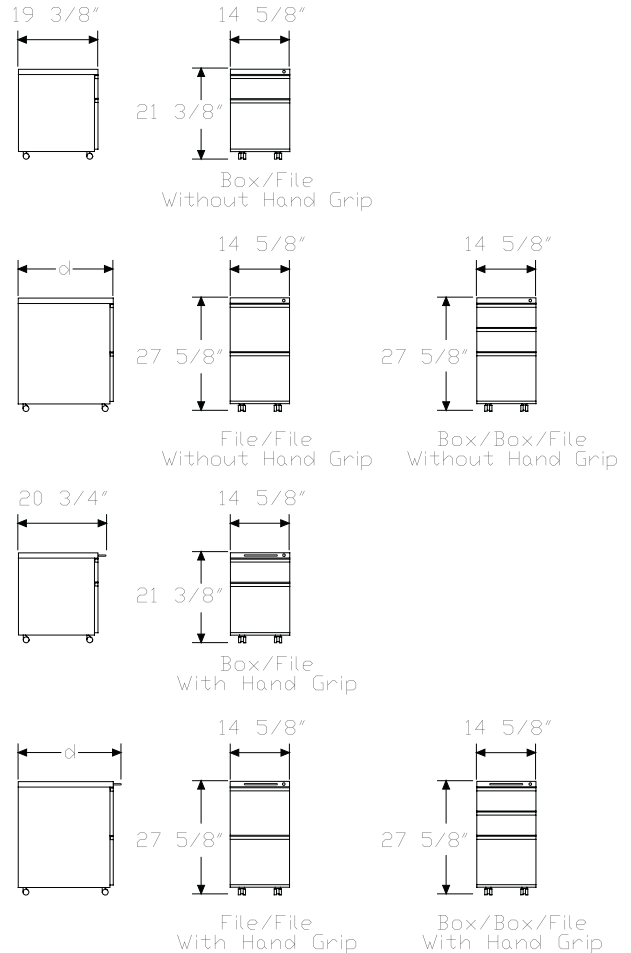

Specification Information

Step 1.

LW110.

Step 2. Depth

20	20" deep
24	24" deep

Step 3. Configuration

For 20" deep (20)

BBF	box/box/file
BF	box/file
FF	file/file

For 24" deep (24)

BBF	box/box/file
FF	file/file

Prices for Steps 1-3.

	BBF	BF	FF
LW110. 20	\$612	515	556
24	\$617	—	564

Step 4. Slides

For box/box/file (BBF)

SR	3/4-extension roller slides on box drawer, full-extension ball bearing on file drawer	+\$0
SB	full-extension ball-bearing	+\$50

For box/file (BF)

SR	3/4-extension roller slides on box drawer, full-extension ball bearing on file drawer	+\$0
SB	full-extension ball-bearing	+\$25

For file/file (FF)

SB	full-extension ball-bearing	+\$0
-----------	-----------------------------	------

Step 5. Paint/Steel Type

SS	smooth paint on smooth steel	+\$0
XS	textured paint on smooth steel	+\$0

Step 6. Surface Finish

For smooth paint on smooth steel (SS)

8Q	folkstone grey	+\$0
98	studio white	+\$0
BU	black umber	+\$0
CN	metallic champagne	+\$40
EH	metallic bronze	+\$40
HF	inner tone light	+\$0
LT	light tone	+\$0
LU	soft white	+\$0
MS	metallic silver	+\$40
MT	medium tone	+\$0
SG	slate grey	+\$0
WL	sandstone	+\$0

Sand Texture Paint

For textured paint on smooth steel (XS)

98	studio white	+\$0
-----------	--------------	------

Bright Sand Texture Paint

For textured paint on smooth steel (XS)

91	white	+\$0
CL	cool grey neutral	+\$0
G1	graphite	+\$0
WN	warm grey neutral	+\$0

Step 7. Lock

KA	keyed alike	+\$0
KC	keyed differently, chrome	+\$0
KD	keyed differently, black	+\$0

Step 8. Drawer Interior

For box/box/file (BBF)

NN	none	+\$0
2M	drawer divider in box drawers, 2 file converters in file drawer	+\$25
3M	drawer divider in one box drawer, pencil tray in one box drawer, 2 file converters in file drawer	+\$25
C51	storage organizer including hanging file holder bin, utility tray and two containers A	+\$120

W-Pull Mobile Pedestal *continued*

For box/file (BF)

NN	none	+\$0
4M	drawer divider in box drawer, 2 file converters in file drawer	+\$20
5M	pencil tray in box drawer, 2 file converters in file drawer	+\$20
C51	storage organizer including hanging file holder bin, utility tray and two containers <input type="checkbox"/> A	+\$120

For file/file (FF)

NN	none	+\$0
1M	2 file converters in each file drawer	+\$25
C51	storage organizer including hanging file holder bin, utility tray and two containers <input type="checkbox"/> A	+\$120

Step 9. Handle

HN	no hand grip	+\$0
H1	hand grip only	+\$48

V-Pull Mobile Pedestal

LV110.

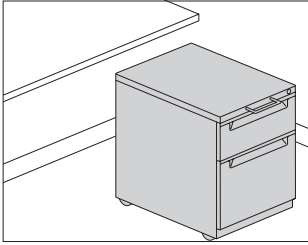

Tu® Metal Storage

Product Information

Description

This mobile pedestal fits below a hanging or freestanding work surface. It has a smooth-steel case, full-width recessed pulls, and black rubber casters. Pedestal can be specified with or without a hand grip.

Counterweight is included.

Actual pedestal depth is $19\frac{3}{8}$ " or $23\frac{3}{4}$ ".

Drawers are available with full-extension or $\frac{3}{4}$ "-extension slides. A drawer divider, utility tray or storage organizer is optional for box drawers. File drawers hold letter-size front-to-back hanging files. File converters are optional for letter-, legal-, and A4-size side-to-side hanging files.

Notes

24"-deep pedestal will not fit below the following products:

- 24"-deep Ethospace® work surface with cable management trough
- Action Office® 60"-wide work surface
- Prospects® 60"-wide work surface

Accepts Tu® add-on cushion top (LG890).

Order optional accessories separately:

- Drawer divider (LG903)
- File compressor (LG908)
- File converter (LG907)
- File drawer organizer (LG901)
- Pedestal stationery divider (LG905)
- Utility tray (LG906)
- Storage organizer (LG910)

Storage organizer includes a hanging file holder, utility tray (pencil tray) and 2 containers. The storage organizer frame color matches the drawer interior; file holder and containers are 91 white; utility tray is black.

For keyed-alike locks, order lock plugs separately. See Keyed-Alike Information in Appendices.

Dimensions

19 3/8"

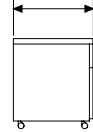

14 5/8"

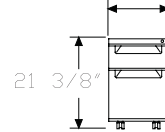

21 3/8"

Box/File
Without Hand Grip

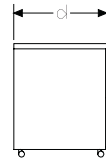

14 5/8"

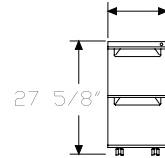

27 5/8"

File/File
Without Hand Grip

14 5/8"

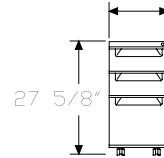

27 5/8"

Box/Box/File
Without Hand Grip

20 3/4"

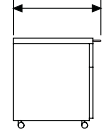

14 5/8"

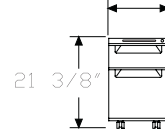

21 3/8"

Box/File
With Hand Grip

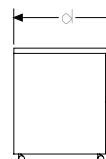

14 5/8"

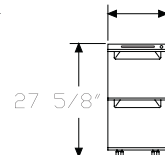

27 5/8"

File/File
With Hand Grip

14 5/8"

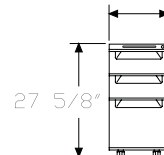

27 5/8"

Box/Box/File
With Hand Grip

Specification Information

Step 1.

LV110.

Step 2. Depth

20	20" deep
24	24" deep

Step 3. Configuration

For 20" deep (20)

BBF	box/box/file
BF	box/file
FF	file/file

For 24" deep (24)

BBF	box/box/file
FF	file/file

Prices for Steps 1-3.

	BBF	BF	FF
LV110. 20	\$631	532	572
24	\$636	—	579

Step 4. Slides

For box/box/file (BBF)

SR	¾-extension roller slides on box drawer, full-extension ball bearing on file drawer	+\$0
SB	full-extension ball-bearing	+\$50

For box/file (BF)

SR	¾-extension roller slides on box drawer, full-extension ball bearing on file drawer	+\$0
SB	full-extension ball-bearing	+\$25

For file/file (FF)

SB	full-extension ball-bearing	+\$0
-----------	-----------------------------	------

Step 5. Paint/Steel Type

SS	smooth paint on smooth steel	+\$0
XS	textured paint on smooth steel	+\$0

Step 6. Surface Finish

For smooth paint on smooth steel (SS)

8Q	folkstone grey	+\$0
98	studio white	+\$0
BU	black umber	+\$0
CN	metallic champagne	+\$40
EH	metallic bronze	+\$40
HF	inner tone light	+\$0
LT	light tone	+\$0
LU	soft white	+\$0
MS	metallic silver	+\$40
MT	medium tone	+\$0
SG	slate grey	+\$0
WL	sandstone	+\$0

Sand Texture Paint

For textured paint on smooth steel (XS)

98	studio white	+\$0
-----------	--------------	------

Bright Sand Texture Paint

For textured paint on smooth steel (XS)

91	white	+\$0
CL	cool grey neutral	+\$0
G1	graphite	+\$0
WN	warm grey neutral	+\$0

Step 7. Lock

KA	keyed alike	+\$0
KC	keyed differently, chrome	+\$0
KD	keyed differently, black	+\$0

Step 8. Drawer Interior

For box/box/file (BBF)

NN	none	+\$0
2M	drawer divider in box drawers, 2 file converters in file drawer	+\$25
3M	drawer divider in one box drawer, pencil tray in one box drawer, 2 file converters in file drawer	+\$25
C51	storage organizer including hanging file holder bin, utility tray and two containers A	+\$120

V-Pull Mobile Pedestal *continued*

Tu® Metal Storage

For box/file (BF)

NN	none	+\$0
4M	drawer divider in box drawer, 2 file converters in file drawer	+\$20
5M	pencil tray in box drawer, 2 file converters in file drawer	+\$20
C51	storage organizer including hanging file holder bin, utility tray and two containers <input type="checkbox"/> A	+\$120

For file/file (FF)

NN	none	+\$0
1M	2 file converters in each file drawer	+\$25
C51	storage organizer including hanging file holder bin, utility tray and two containers <input type="checkbox"/> A	+\$120

Step 9. Handle

HN	no hand grip	+\$0
H1	hand grip only	+\$48

Bar Pull Surface-Attached Pedestal

LK14A.
LK14D.

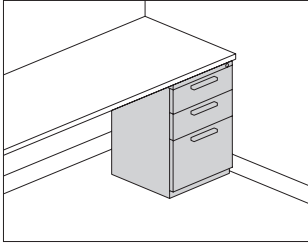

Product Information

Description

This pedestal attaches under a work surface on the left or right side to provide support and eliminates the need for a cantilever. It has a painted or veneer front, smooth-steel case, applied metal bar pulls, and 1" leveling glides. Attachment hardware is included.

Actual pedestal height is 27¹/₄". Height with squared-edge laminate or veneer work surface is 28¹/₂". Height with squared- or eased-edge Formcoat™ work surface is 28³/₄". Actual pedestal depth is 19³/₈", 22⁷/₈", or 28⁷/₈". Pedestal does not work with thin-edge work surfaces.

For freestanding applications, the 24"-deep pedestal depth matches a 24"-deep Canvas or Ethospace® work surface. The 30"-deep pedestal depth matches a 30"-deep Canvas or Ethospace work surface.

Box drawers are available with full-extension or 3/4"-extension slides.

File drawers have full-extension slides. A drawer divider, utility tray or storage organizer is optional for box drawers. File drawers hold letter-size front-to-back hanging files. File converters are optional for letter-, legal-, and A4-size side-to-side hanging files.

Notes

Base on 27¹/₄"-high (raised height) unit (2F) aligns with base on Tu® storage towers.

For full extension slides on box drawers, specify option (SB).

Grain direction is vertical for veneer-front pedestals.

To add file converters, drawer divider, pencil tray, or storage organizer to drawer interiors, specify drawer interior option (1M), (2M), (3M) or (C51).

Order optional accessories separately:

- Drawer divider (LG903.)
- File compressor (LG908)
- File converter (LG907)
- File drawer organizer (LG901)
- Pedestal stationery divider (LG905)
- Utility tray (LG906)
- Storage organizer (LG910)

Storage organizer includes a hanging file holder, utility tray (pencil tray) and 2 containers. Storage organizer frame color matches drawer interior; file holder and containers are 91 white; utility tray is black.

For keyed-alike locks, order lock plugs separately. See Keyed-Alike Information in Appendices.

Dimensions

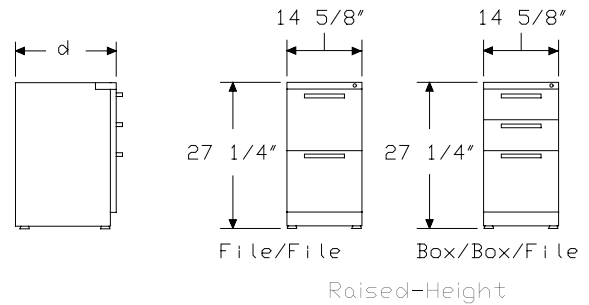

Bar Pull Surface-Attached Pedestal *continued*

Tu® Metal Storage

Specification Information

Step 1.

LK14

Step 2. Front Material

- D.** painted metal front
- A.** veneer front A

Step 3. Depth

- 20** 20" deep
- 24** 24" deep
- 28** 28" deep

Step 4. Configuration

- BBF** box/box/file
- FF** file/file

Prices for Steps 1-4.

	BBF	FF
LK14D. 20	\$593	609
24	\$628	645
28	\$693	710
LK14A. 20	\$821	839
24	\$858	877
28	\$924	942

Step 5. Slides

For box/box/file (BBF)

- SR** ¾-extension roller slides on box drawer, full-extension ball bearing on file drawer +\$0
- SB** full-extension ball-bearing +\$50

For file/file (FF)

- SB** full-extension ball-bearing +\$0

Step 6. Paint/Steel Type

- SS** smooth paint on smooth steel +\$0
- XS** textured paint on smooth steel +\$0

Step 7. Surface Finish

For smooth paint on smooth steel (SS)

- 8Q** folkstone grey +\$0
- 98** studio white +\$0
- BU** black umber +\$0
- CN** metallic champagne +\$40
- EH** metallic bronze +\$40
- HF** inner tone light +\$0
- LT** light tone +\$0
- LU** soft white +\$0
- MS** metallic silver +\$40
- MT** medium tone +\$0
- SG** slate grey +\$0
- WL** sandstone +\$0

Sand Texture Paint

For textured paint on smooth steel (XS)

- 98** studio white +\$0

Bright Sand Texture Paint

For textured paint on smooth steel (XS)

- 91** white +\$0
- CL** cool grey neutral +\$0
- G1** graphite +\$0
- WN** warm grey neutral +\$0

Step 8. Front Finish

For veneer front (A.)

Recut Veneer

- RA** light ash A +\$0
- RK** mahogany dark A +\$0
- RM** mahogany A +\$0
- 2U** light brown walnut A +\$107
- 40** dark brown walnut A +\$107
- ED** aged cherry A +\$107
- EK** medium red walnut A +\$107
- EW** medium matte walnut A +\$107
- ET** clear on ash A +\$107
- EV** walnut on ash A +\$107
- UL** natural maple A +\$107
- UX** walnut on cherry A +\$107

Bar Pull Surface-Attached Pedestal *continued*

Step 9. Lock		
KA	keyed alike	+\$0
KC	keyed differently, chrome	+\$0
KD	keyed differently, black	+\$0

Step 10. Pull Finish		
8Q	folkstone grey	+\$0
91	white	+\$0
98	studio white	+\$0
G1	graphite <input type="checkbox"/> A	+\$0
WL	sandstone <input type="checkbox"/> A	+\$0
CN	metallic champagne <input type="checkbox"/> A	+\$0
MS	metallic silver	+\$0
79	green apple <input type="checkbox"/> A	+\$15
MY3	yellow oxide <input type="checkbox"/> A	+\$15
RO	red <input type="checkbox"/> A	+\$15
TRQ	turquoise <input type="checkbox"/> A	+\$15

Step 11. Base Height		
2F	27 ¹ / ₄ " high (raised height)	+\$0

Step 12. Drawer Interior

<i>For box/box/file (BBF)</i>		
NN	none	+\$0
2M	drawer divider in box drawers, 2 file converters in file drawer	+\$25
3M	drawer divider in one box drawer, pencil tray in one box drawer, 2 file converters in file drawer	+\$25
C51	storage organizer including hanging file holder bin, utility tray and two containers <input type="checkbox"/> A	+\$120

<i>For file/file (FF)</i>		
NN	none	+\$0
1M	2 file converters in each file drawer	+\$25
C51	storage organizer including hanging file holder bin, utility tray and two containers <input type="checkbox"/> A	+\$120

Arc Pull Surface-Attached Pedestal

LQ14A.
LQ14D.

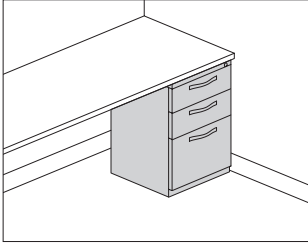

Tu® Metal Storage

Product Information

Description

This pedestal attaches under a work surface on the left or right side to provide support and eliminates the need for a cantilever. It has a painted or veneer front, smooth-steel case, applied metal arc pulls, and 1" leveling glides. Attachment hardware is included.

Actual pedestal height is 27¹/₄". Height with squared-edge laminate or veneer work surface is 28¹/₂". Height with squared- or eased-edge Formcoat™ work surface is 28³/₄". Actual pedestal depth is 19³/₈", 22⁷/₈", or 28⁷/₈". Pedestal does not work with thin-edge work surfaces

For freestanding applications, the 24"-deep pedestal depth matches a 24"-deep Canvas or Ethospace® work surface. The 30"-deep pedestal depth matches a 30"-deep Canvas or Ethospace work surface.

Box drawers are available with full-extension or 3/4"-extension slides. File drawers have full-extension slides. A drawer divider, utility tray or storage organizer is optional for box drawers. File drawers hold letter-size front-to-back hanging files. File converters are optional for letter-, legal-, and A4-size side-to-side hanging files.

Notes

Pull design conforms to guidelines of Americans with Disabilities Act (ADA).

Base on 27¹/₄"-high (raised height) unit (2F) aligns with base on Tu® storage towers.

For full extension slides on box drawers, specify option (SB).

Grain direction is vertical for veneer-front pedestals.

To add file converters, drawer divider, pencil tray, or storage organizer to drawer interiors, specify drawer interior option (1M), (2M), (3M) or (C51).

Order optional accessories separately:

- Drawer divider (LG903.)
- File compressor (LG908)
- File converter (LG907)
- File drawer organizer (LG901)
- Pedestal stationery divider (LG905)
- Utility tray (LG906)
- Storage organizer (LG910)

Storage organizer includes a hanging file holder, utility tray (pencil tray) and 2 containers. The storage organizer frame color matches the drawer interior; file holder and containers are 91 white; utility tray is black.

For keyed-alike locks, order lock plugs separately. See Keyed-Alike Information in Appendices.

Dimensions

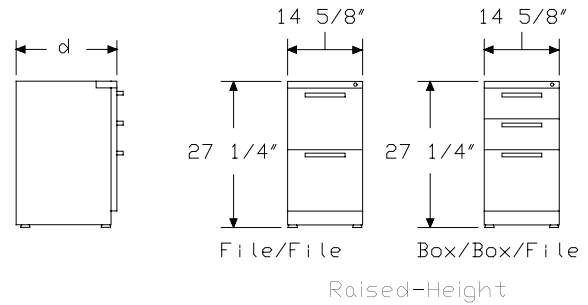

Arc Pull Surface-Attached Pedestal *continued*

Specification Information

Step 1.

LQ14

Step 2. Front Material

- D.** painted metal front
- A.** veneer front A

Step 3. Depth

- 20** 20" deep
- 24** 24" deep
- 28** 28" deep

Step 4. Configuration

- BBF** box/box/file
- FF** file/file

Prices for Steps 1-4.

	BBF	FF
LQ14D. 20	\$593	609
24	\$628	645
28	\$693	710
LQ14A. 20	\$821	839
24	\$858	877
28	\$924	942

Step 5. Slides

For box/box/file (BBF)

- SR** ¾-extension roller slides on box drawer, full-extension ball bearing on file drawer +\$0
- SB** full-extension ball-bearing +\$50

For file/file (FF)

- SB** full-extension ball-bearing +\$0

Step 6. Paint/Steel Type

- SS** smooth paint on smooth steel +\$0
- XS** textured paint on smooth steel +\$0

Step 7. Surface Finish

For smooth paint on smooth steel (SS)

- 8Q** folkstone grey +\$0
- 98** studio white +\$0
- BU** black umber +\$0
- CN** metallic champagne +\$40
- EH** metallic bronze +\$40
- HF** inner tone light +\$0
- LT** light tone +\$0
- LU** soft white +\$0
- MS** metallic silver +\$40
- MT** medium tone +\$0
- SG** slate grey +\$0
- WL** sandstone +\$0

Sand Texture Paint

For textured paint on smooth steel (XS)

- 98** studio white +\$0

Bright Sand Texture Paint

For textured paint on smooth steel (XS)

- 91** white +\$0
- CL** cool grey neutral +\$0
- G1** graphite +\$0
- WN** warm grey neutral +\$0

Step 8. Front Finish

For veneer front (A.)

Recut Veneer

- RA** light ash A +\$0
- RK** mahogany dark A +\$0
- RM** mahogany A +\$0

Wood Veneer

- 2U** light brown walnut A +\$107
- 40** dark brown walnut A +\$107
- ED** aged cherry A +\$107
- EK** medium red walnut A +\$107
- EW** medium matte walnut A +\$107
- ET** clear on ash A +\$107
- EU** oak on ash A +\$107
- EV** walnut on ash A +\$107
- UL** natural maple A +\$107
- UX** walnut on cherry A +\$107

Arc Pull Surface-Attached Pedestal *continued*

Tu® Metal Storage

Step 9. Lock

KA	keyed alike	+\$0
KC	keyed differently, chrome	+\$0
KD	keyed differently, black	+\$0

Step 10. Pull Finish

NH	brushed nickel	+\$0
NK	black nickel	+\$0

Step 11. Base Height

2F	27 ¹ / ₄ " high (raised height)	+\$0
-----------	---	------

Step 12. Drawer Interior

For box/box/file (BBF)

NN	none	+\$0
2M	drawer divider in box drawers, 2 file converters in file drawer	+\$25
3M	drawer divider in one box drawer, pencil tray in one box drawer, 2 file converters in file drawer	+\$25
C51	storage organizer including hanging file holder bin, utility tray and two containers <input type="checkbox"/> A	+\$120

For file/file (FF)

NN	none	+\$0
1M	2 file converters in each file drawer	+\$25
C51	storage organizer including hanging file holder bin, utility tray and two containers <input type="checkbox"/> A	+\$120

W-Pull Surface-Attached Pedestal LW140.

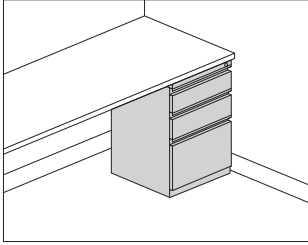

Product Information

Description

This pedestal attaches under a work surface on the left or right side to provide support and eliminates the need for a cantilever. It has a painted metal front, smooth-steel case, full-width recessed pulls, and 1" leveling glides. Attachment hardware is included.

Actual pedestal height is 27¹/₄". Height with squared-edge laminate or veneer work surface is 28¹/₂". Height with squared- or eased-edge Formcoat™ work surface is 28³/₄". Actual pedestal depth is 19³/₈", 22⁷/₈", or 28⁷/₈". Pedestal does not work with thin-edge work surfaces.

For freestanding applications, the 24"-deep pedestal depth matches a 24"-deep Canvas or Ethospace® work surface. The 30"-deep pedestal depth matches a 30"-deep Canvas or Ethospace work surface.

Box drawers are available with full-extension or ¾-extension slides. File drawers have full-extension slides. A drawer divider, utility tray or storage organizer is optional for box drawers. File drawers hold letter-size front-to-back hanging files. File converters are optional for letter-, legal-, and A4-size side-to-side hanging files.

Notes

Base on 27¹/₄"-high (raised height) unit (2F) aligns with base on Tu® storage towers.

For full extension slides on box drawers, specify option (SB).

To add file converters, drawer divider, pencil tray, or storage organizer to drawer interiors, specify drawer interior option (1M), (2M), (3M) or (C51).

Order optional accessories separately:

- Drawer divider (LG903.)
- File compressor (LG908)
- File converter (LG907)
- File drawer organizer (LG901)
- Pedestal stationery divider (LG905)
- Utility tray (LG906)
- Storage organizer (LG910)

Storage organizer includes a hanging file holder, utility tray (pencil tray) and 2 containers. The storage organizer frame color matches the drawer interior; file holder and containers are 91 white; utility tray is black.

For keyed-alike locks, order lock plugs separately. See Keyed-Alike Information in Appendices.

Dimensions

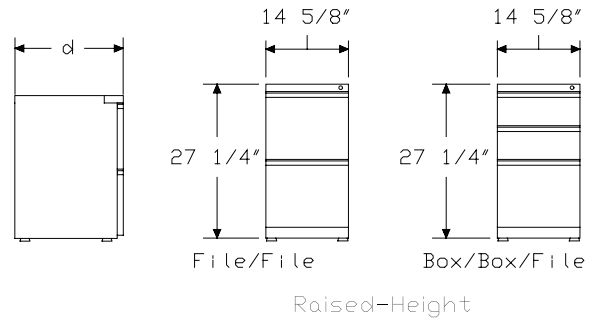

W-Pull Surface-Attached Pedestal

continued

Tu® Metal Storage

Specification Information		
Step 1.		
LW140.		
Step 2. Depth		
20	20" deep	
24	24" deep	
28	28" deep	
Step 3. Configuration		
BBF	box/box/file	
FF	file/file	
Prices for Steps 1-3.		
		BBF FF
LW140. 20		\$523 478
24		\$537 490
28		\$627 576
Step 4. Slides		
<i>For box/box/file (BBF)</i>		
SR	3/4"-extension roller slides on box drawer, full-extension ball bearing on file drawer	+\$0
SB	full-extension ball-bearing	+\$50
<i>For file/file (FF)</i>		
SB	full-extension ball-bearing	+\$0
Step 5. Paint/Steel Type		
SS	smooth paint on smooth steel	+\$0
XS	textured paint on smooth steel	+\$0

Step 6. Surface Finish		
<i>For smooth paint on smooth steel (SS)</i>		
8Q	folkstone grey	+\$0
98	studio white	+\$0
BU	black umber	+\$0
CN	metallic champagne	+\$40
EH	metallic bronze	+\$40
HF	inner tone light	+\$0
LT	light tone	+\$0
LU	soft white	+\$0
MS	metallic silver	+\$40
MT	medium tone	+\$0
SG	slate grey	+\$0
WL	sandstone	+\$0
Sand Texture Paint		
<i>For textured paint on smooth steel (XS)</i>		
98	studio white	+\$0
Bright Sand Texture Paint		
<i>For textured paint on smooth steel (XS)</i>		
91	white	+\$0
CL	cool grey neutral	+\$0
G1	graphite	+\$0
WN	warm grey neutral	+\$0
Step 7. Lock		
KA	keyed alike	+\$0
KD	keyed differently, black	+\$0
KC	keyed differently, chrome	+\$0
Step 8. Base Height		
2F	27 1/4" high (raised height)	+\$0
Step 9. Drawer Interior		
<i>For 20" deep (20) or 24" deep (24) with box/box/file (BBF)</i>		
NN	none	+\$0
2M	drawer divider in box drawers, 2 file converters in file drawer	+\$25
3M	drawer divider in one box drawer, pencil tray in one box drawer, 2 file converters in file drawer	+\$25
C51	storage organizer including hanging file holder bin, utility tray and two containers A	+\$120

W-Pull Surface-Attached Pedestal

continued

For 28" deep (28) with box/box/file (BBF)

NN	none	+\$0
2M	drawer divider in box drawers, 2 file converters in file drawer	+\$25
3M	drawer divider in one box drawer, pencil tray in one box drawer, 2 file converters in file drawer	+\$25

For 20" deep (20) or 24" deep (24) with file/file (FF)

NN	none	+\$0
1M	2 file converters in each file drawer	+\$25
C51	storage organizer including hanging file holder bin, utility tray and two containers A	+\$120

For 28" deep (28) with file/file (FF)

NN	none	+\$0
1M	2 file converters in each file drawer	+\$25

V-Pull Surface-Attached Pedestal LV140.

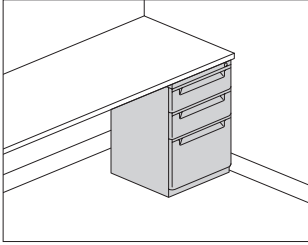

Tu® Metal Storage

Product Information

Description

This pedestal attaches under a work surface on the left or right side to provide support and eliminates the need for a cantilever. It has a painted metal front, smooth-steel case, full-width recessed pulls, and 1" leveling glides. Attachment hardware is included.

Actual pedestal height is 27¹/₄". Height with squared-edge laminate or veneer work surface is 28¹/₂". Height with squared- or eased-edge Formcoat™ work surface is 28¹/₄". Actual pedestal depth is 19³/₈", 22⁷/₈", or 28⁷/₈". Pedestal does not work with thin-edge work surfaces

For freestanding applications, the 24"-deep pedestal depth matches a 24"-deep Canvas or Ethospace® work surface. The 30"-deep pedestal depth matches a 30"-deep Canvas or Ethospace work surface.

Box drawers are available with full-extension or 3/4-extension slides.

File drawers have full-extension slides. A drawer divider, utility tray or storage organizer is optional for box drawers. File drawers hold letter-size front-to-back hanging files. File converters are optional for letter-, legal-, and A4-size side-to-side hanging files.

Notes

Base on 27¹/₄"-high (raised height) unit (2F) aligns with base on Tu® storage towers.

For full extension slides on box drawers, specify option (SB).

To add file converters, drawer divider, pencil tray, or storage organizer to drawer interiors, specify drawer interior option (1M), (2M), (3M) or (C51).

Order optional accessories separately:

- Drawer divider (LG903.)
- File compressor (LG908)
- File converter (LG907)
- File drawer organizer (LG901)
- Pedestal stationery divider (LG905)
- Utility tray (LG906)
- Storage organizer (LG910)

Storage organizer includes a hanging file holder, utility tray (pencil tray) and 2 containers. The storage organizer frame color matches the drawer interior; file holder and containers are 91 white; utility tray is black.

For keyed-alike locks, order lock plugs separately. See Keyed-Alike Information in Appendices.

Dimensions

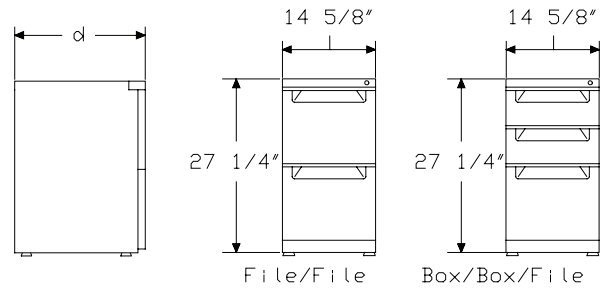

Raised-Height

V-Pull Surface-Attached Pedestal

continued

Specification Information

Step 1.

LV140.

Step 2. Depth

20	20" deep
24	24" deep
28	28" deep

Step 3. Configuration

BBF	box/box/file
FF	file/file

Prices for Steps 1-3.

	BBF	FF
LV140. 20	\$535	491
24	\$552	503
28	\$622	569

Step 4. Slides

For box/box/file (BBF)

SR	¾-extension roller slides on box drawer, full-extension ball bearing on file drawer	+\$0
SB	full-extension ball-bearing	+\$50

For file/file (FF)

SB	full-extension ball-bearing	+\$0
-----------	-----------------------------	------

Step 5. Paint/Steel Type

SS	smooth paint on smooth steel	+\$0
XS	textured paint on smooth steel	+\$0

Step 6. Surface Finish

For smooth paint on smooth steel (SS)

8Q	folkstone grey	+\$0
98	studio white	+\$0
BU	black umber	+\$0
CN	metallic champagne	+\$40
EH	metallic bronze	+\$40
HF	inner tone light	+\$0
LT	light tone	+\$0
LU	soft white	+\$0
MS	metallic silver	+\$40
MT	medium tone	+\$0
SG	slate grey	+\$0
WL	sandstone	+\$0

Sand Texture Paint

For textured paint on smooth steel (XS)

98	studio white	+\$0
-----------	--------------	------

Bright Sand Texture Paint

For textured paint on smooth steel (XS)

91	white	+\$0
CL	cool grey neutral	+\$0
G1	graphite	+\$0
WN	warm grey neutral	+\$0

Step 7. Lock

KA	keyed alike	+\$0
KC	keyed differently, chrome	+\$0
KD	keyed differently, black	+\$0

Step 8. Base Height

2F	27¼" high (raised height)	+\$0
-----------	---------------------------	------

Step 9. Drawer Interior

For 20" deep (20) or 24" deep (24) with box/box/file (BBF)

NN	none	+\$0
2M	drawer divider in box drawers, 2 file converters in file drawer	+\$25
3M	drawer divider in one box drawer, pencil tray in one box drawer, 2 file converters in file drawer	+\$25
C51	storage organizer including hanging file holder bin, utility tray and two containers A	+\$120

V-Pull Surface-Attached Pedestal

continued

Tu[®] Metal Storage

For 28" deep (28) with box/box/file (BBF)

NN	none	+\$0
2M	drawer divider in box drawers, 2 file converters in file drawer	+\$25
3M	drawer divider in one box drawer, pencil tray in one box drawer, 2 file converters in file drawer	+\$25

For 20" deep (20) or 24" deep (24) with file/file (FF)

NN	none	+\$0
1M	2 file converters in each file drawer	+\$25
C51	storage organizer including hanging file holder bin, utility tray and two containers A	+\$120

For 28" deep (28) with file/file (FF)

NN	none	+\$0
1M	2 file converters in each file drawer	+\$25

Bar Pull Support Pedestal

LK15A.
LK15D.

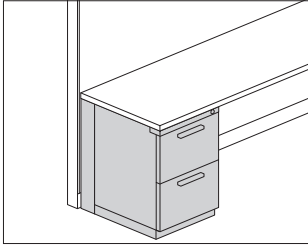

Product Information

Description

This pedestal attaches to both a work surface and a panel or frame at the end of a run or mid-run to provide support. It eliminates the need for a return panel/frame and connector or a work surface support panel. It has a painted or veneer front, smooth-steel case, applied metal bar pulls, and 1 3/4" leveling glides. The pedestal attaches under a work surface on the left or right side. Attachment hardware and support bracket are included.

The actual pedestal depth is 19 3/8", 23 1/4", or 27 3/4". A 20"-deep pedestal supports a 24"-deep work surface. A 24"-deep pedestal supports a 30"-deep Ethospace® work surface with a cable management trough. A 28"-deep pedestal supports a 30"-deep work surface.

Box drawers are available with full-extension or 3/4"-extension slides. File drawers have full-extension slides and hold letter-size front-to-back hanging files.

Notes

To add drawer divider, pencil tray, and file converters to drawer interiors, specify option (2M) or (3M).

For full extension slides on box drawers, specify option (SB).

Grain direction is vertical for veneer-front pedestals.

Order optional accessories separately:

- Drawer divider (LG903.)
- File compressor (LG908)
- File converter (LG907)
- File drawer organizer (LG901)
- Pedestal stationery divider (LG905)
- Utility tray (LG906)
- Storage organizer (LG910)

Storage organizer includes a hanging file holder, utility tray (pencil tray) and 2 containers. Storage organizer frame color matches drawer interior; file holder and containers are 91 white; utility tray is black.

For keyed-alike locks, order lock plugs separately. See Keyed-Alike Information in Appendices.

Dimensions

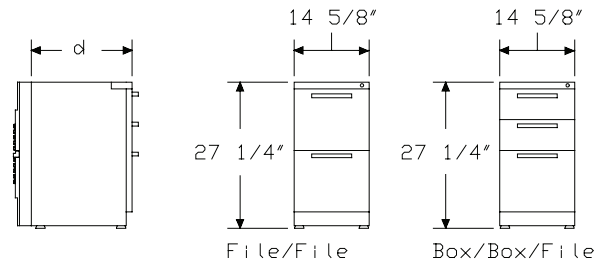

Bar Pull Support Pedestal *continued*

Tu® Metal Storage

Specification Information		
Step 1.		
LK15		
Step 2. Front Material		
D.	painted metal front	
A.	veneer front <input type="checkbox"/>	
Step 3. Depth		
20	20" deep	
24	24" deep	
28	28" deep	
Step 4. Configuration		
BBF	box/box/file	
FF	file/file	
Prices for Steps 1-4.		
	BBF	FF
LK15D. 20	\$719	693
24	\$820	781
28	\$920	873
LK15A. 20	\$951	924
24	\$1056	1015
28	\$1156	1108
Step 5. Slides		
<i>For box/box/file (BBF)</i>		
SR	3/4-extension roller slides on box drawer, full-extension ball bearing on file drawer	+\$0
SB	full-extension ball-bearing	+\$50
<i>For file/file (FF)</i>		
SB	full-extension ball-bearing	+\$0
Step 6. Paint/Steel Type		
SS	smooth paint on smooth steel	+\$0
XS	textured paint on smooth steel	+\$0

Step 7. Surface Finish		
<i>For smooth paint on smooth steel (SS)</i>		
8Q	folkstone grey	+\$0
98	studio white	+\$0
BU	black umber	+\$0
CN	metallic champagne	+\$40
EH	metallic bronze	+\$40
HF	inner tone light	+\$0
LT	light tone	+\$0
LU	soft white	+\$0
MS	metallic silver	+\$40
MT	medium tone	+\$0
SG	slate grey	+\$0
WL	sandstone	+\$0
Sand Texture Paint		
<i>For textured paint on smooth steel (XS)</i>		
98	studio white	+\$0
Bright Sand Texture Paint		
<i>For textured paint on smooth steel (XS)</i>		
91	white	+\$0
CL	cool grey neutral	+\$0
G1	graphite	+\$0
WN	warm grey neutral	+\$0
Step 8. Attachment Bracket		
1A	for Action Office® Series 1 and 2 radiused-edge work surface	+\$0
2A	for Action Office® Series 1 and 2 squared-edge work surface	+\$0
E1	for Ethospace® System	+\$0
F8	for Canvas Office Landscape®	+\$0
Step 9. Front Finish		
<i>For veneer front (A.)</i>		
Recut Veneer		
RA	light ash <input type="checkbox"/>	+\$0
RK	mahogany dark <input type="checkbox"/>	+\$0
RM	mahogany <input type="checkbox"/>	+\$0

Bar Pull Support Pedestal *continued*

Wood Veneer

2U	light brown walnut <input type="checkbox"/>	+\$107
40	dark brown walnut <input type="checkbox"/>	+\$107
ED	aged cherry <input type="checkbox"/>	+\$107
EK	medium red walnut <input type="checkbox"/>	+\$107
EW	medium matte walnut <input type="checkbox"/>	+\$107
ET	clear on ash <input type="checkbox"/>	+\$107
EV	walnut on ash <input type="checkbox"/>	+\$107
UL	natural maple <input type="checkbox"/>	+\$107
UX	walnut on cherry <input type="checkbox"/>	+\$107

Step 10. Lock

KA	keyed alike	+\$0
KC	keyed differently, chrome	+\$0
KD	keyed differently, black	+\$0

Step 11. Pull Finish

8Q	folkstone grey	+\$0
91	white	+\$0
98	studio white	+\$0
G1	graphite <input type="checkbox"/>	+\$0
WL	sandstone <input type="checkbox"/>	+\$0
CN	metallic champagne <input type="checkbox"/>	+\$0
MS	metallic silver	+\$0
79	green apple <input type="checkbox"/>	+\$15
MY3	yellow oxide <input type="checkbox"/>	+\$15
RO	red <input type="checkbox"/>	+\$15
TRQ	turquoise <input type="checkbox"/>	+\$15
XX	no pull	+\$0

Step 12. Drawer Interior

For box/box/file (BBF)

NN	none	+\$0
2M	drawer divider in box drawers, 2 file converters in file drawer	+\$25
3M	drawer divider in one box drawer, pencil tray in one box drawer, 2 file converters in file drawer	+\$25
C51	storage organizer including hanging file holder bin, utility tray and two containers <input type="checkbox"/>	+\$120

For file/file (FF)

NN	none	+\$0
1M	2 file converters in each file drawer	+\$25
C51	storage organizer including hanging file holder bin, utility tray and two containers <input type="checkbox"/>	+\$120

Arc Pull Support Pedestal

LQ15A.
LQ15D.

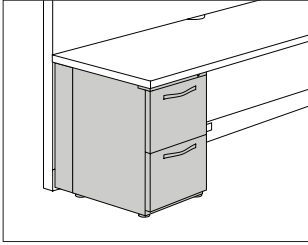

Tu® Metal Storage

Product Information

Description

This pedestal attaches to both a work surface and a panel or frame at the end of a run or mid-run to provide support. It eliminates the need for a return panel/frame and connector or a work surface support panel. It has a painted or veneer front, smooth-steel case, applied metal arc pulls, and 1 3/4" leveling glides. The pedestal attaches under a work surface on the left or right side. Attachment hardware and support bracket are included.

The actual pedestal depth is 19 3/8", 23 3/4", or 27 3/4". A 20"-deep pedestal supports a 24"-deep work surface. A 24"-deep pedestal supports a 30"-deep Ethospace® work surface with a cable management trough. A 28"-deep pedestal supports a 30"-deep work surface.

Box drawers are available with full-extension or 3/4"-extension slides. File drawers have full-extension slides and hold letter-size front-to-back hanging files.

Notes

Pull design conforms to guidelines of Americans with Disabilities Act (ADA).

To add drawer divider, pencil tray, file converters and storage organizer to drawer interiors, specify option (1M), (2M), (3M) or (C51).

For full extension slides on box drawers, specify option (SB).

Grain direction is vertical for veneer-front pedestals.

Order optional accessories separately:

- Drawer divider (LG903.)
- File compressor (LG908)
- File converter (LG907)
- File drawer organizer (LG901)
- Pedestal stationery divider (LG905)
- Utility tray (LG906)
- Storage organizer (LG910)

Storage organizer includes a hanging file holder, utility tray (pencil tray) and 2 containers. The storage organizer frame color matches the drawer interior; file holder and containers are 91 white; utility tray is black.

For keyed-alike locks, order lock plugs separately. See Keyed-Alike Information in Appendices.

Dimensions

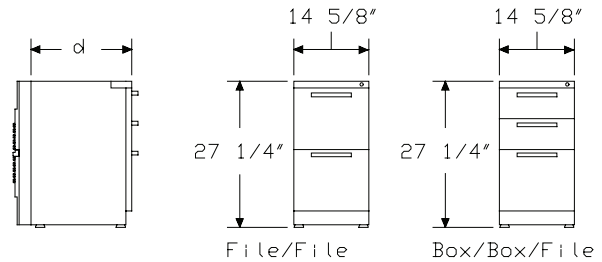

File/File

Box/Box/File

Specification Information

Step 1.

LQ15

Step 2. Front Material

- D.** painted metal front
- A.** veneer front A

Step 3. Depth

- 20** 20" deep
- 24** 24" deep
- 28** 28" deep

Step 4. Configuration

- BBF** box/box/file
- FF** file/file

Prices for Steps 1-4.

	BBF	FF
LQ15D. 20	\$719	693
24	\$820	781
28	\$920	873
LQ15A. 20	\$951	924
24	\$1056	1015
28	\$1156	1108

Step 5. Slides

For box/box/file (BBF)

- SR** ¾-extension roller slides on box drawer, full-extension ball bearing on file drawer +\$0
- SB** full-extension ball-bearing +\$50

For file/file (FF)

- SB** full-extension ball-bearing +\$0

Step 6. Paint/Steel Type

- SS** smooth paint on smooth steel +\$0
- XS** textured paint on smooth steel +\$0

Step 7. Surface Finish

For smooth paint on smooth steel (SS)

- 8Q** folkstone grey +\$0
- 98** studio white +\$0
- BU** black umber +\$0
- CN** metallic champagne +\$40
- EH** metallic bronze +\$40
- HF** inner tone light +\$0
- LT** light tone +\$0
- LU** soft white +\$0
- MS** metallic silver +\$40
- MT** medium tone +\$0
- SG** slate grey +\$0
- WL** sandstone +\$0

Sand Texture Paint

For textured paint on smooth steel (XS)

- 98** studio white +\$0

Bright Sand Texture Paint

For textured paint on smooth steel (XS)

- 91** white +\$0
- CL** cool grey neutral +\$0
- G1** graphite +\$0
- WN** warm grey neutral +\$0

Step 8. Attachment Bracket

- 1A** for Action Office® Series 1 and 2 radiused-edge work surface +\$0
- 2A** for Action Office® Series 1 and 2 squared-edge work surface +\$0
- E1** for Ethospace® System +\$0
- F8** for Canvas Office Landscape® +\$0

Step 9. Front Finish

For veneer front (A.)

Recut Veneer

- RA** light ash A +\$0
- RK** mahogany dark A +\$0
- RM** mahogany A +\$0

Arc Pull Support Pedestal *continued*

Tu® Metal Storage

Wood Veneer		
2U	light brown walnut <input type="checkbox"/> A	+\$107
40	dark brown walnut <input type="checkbox"/> A	+\$107
ED	aged cherry <input type="checkbox"/> A	+\$107
EK	medium red walnut <input type="checkbox"/> A	+\$107
EW	medium matte walnut <input type="checkbox"/> A	+\$107
ET	clear on ash <input type="checkbox"/> A	+\$107
EU	oak on ash <input type="checkbox"/> A	+\$107
EV	walnut on ash <input type="checkbox"/> A	+\$107
UL	natural maple <input type="checkbox"/> A	+\$107
UX	walnut on cherry <input type="checkbox"/> A	+\$107

Step 10. Lock		
KA	keyed alike	+\$0
KC	keyed differently, chrome	+\$0
KD	keyed differently, black	+\$0

Step 11. Pull Finish		
NH	brushed nickel	+\$0
NK	black nickel	+\$0

Step 12. Drawer Interior

For box/box/file (BBF)		
NN	none	+\$0
2M	drawer divider in box drawers, 2 file converters in file drawer	+\$25
3M	drawer divider in one box drawer, pencil tray in one box drawer, 2 file converters in file drawer	+\$25
C51	storage organizer including hanging file holder bin, utility tray and two containers <input type="checkbox"/> A	+\$120

For file/file (FF)		
NN	none	+\$0
1M	2 file converters in each file drawer	+\$25
C51	storage organizer including hanging file holder bin, utility tray and two containers <input type="checkbox"/> A	+\$120

W-Pull Support Pedestal

LW150.

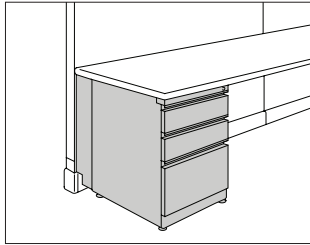

Product Information

Description

This pedestal attaches to both a work surface and a panel or frame at either the end of a run or mid-run to provide support. It eliminates the need for a return panel/frame and connector or a work surface support panel. It has a smooth-steel case, full-width pulls, and 1 3/4" leveling glides. It attaches under a work surface on the left or right side.

Attachment hardware and support bracket are included.

The actual pedestal depth is 19 3/8", 23 1/4", or 27 3/4". A 20"-deep pedestal supports a 24"-deep work surface. A 24"-deep pedestal supports a 30"-deep Ethospace® work surface with cable management trough. A 28"-deep pedestal supports a 30"-deep work surface.

Drawers are available with full-extension or 3/4-extension slides. A drawer divider, utility tray or storage organizer is optional for box drawers. File drawers hold letter-size front-to-back hanging files. File converters are optional for letter-, legal-, and A4-size side-to-side hanging files.

Notes

Order optional accessories separately:

- Drawer divider (LG903.)
- File compressor (LG908)
- File converter (LG907)
- File drawer organizer (LG901)
- Pedestal stationery divider (LG905)
- Utility tray (LG906)
- Storage organizer (LG910)

Storage organizer includes a hanging file holder, utility tray (pencil tray) and 2 containers. The storage organizer frame color matches the drawer interior; file holder and containers are 91 white; utility tray is black.

For keyed-alike locks, order lock plugs separately. See Keyed-Alike Information in Appendices.

Dimensions

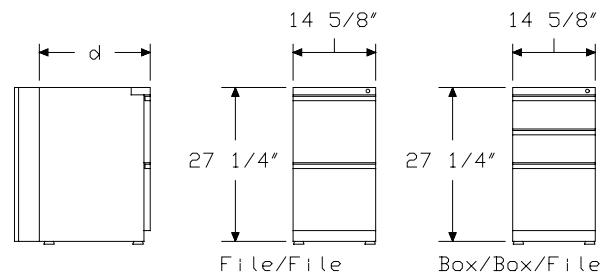

Specification Information

Step 1.

LW150.

Step 2. Depth

20	20" deep
24	24" deep
28	28" deep

Step 3. Configuration

BBF	box/box/file
FF	file/file

Prices for Steps 1-3.

	BBF	FF
LW150. 20	\$599	556
24	\$627	597
28	\$661	633

Step 4. Slides

For box/box/file (BBF)

SR	3/4"-extension roller slides on box drawer, full-extension ball bearing on file drawer	+\$0
SB	full-extension ball-bearing	+\$50

For file/file (FF)

SB	full-extension ball-bearing	+\$0
-----------	-----------------------------	------

Step 5. Paint/Steel Type

SS	smooth paint on smooth steel	+\$0
XS	textured paint on smooth steel	+\$0

Step 6. Surface Finish

For smooth paint on smooth steel (SS)

8Q	folkstone grey	+\$0
98	studio white	+\$0
BU	black umber	+\$0
CN	metallic champagne	+\$40
EH	metallic bronze	+\$40
HF	inner tone light	+\$0
LT	light tone	+\$0
LU	soft white	+\$0
MS	metallic silver	+\$40
MT	medium tone	+\$0
SG	slate grey	+\$0
WL	sandstone	+\$0

Sand Texture Paint

For textured paint on smooth steel (XS)

98	studio white	+\$0
-----------	--------------	------

Bright Sand Texture Paint

For textured paint on smooth steel (XS)

91	white	+\$0
CL	cool grey neutral	+\$0
G1	graphite	+\$0
WN	warm grey neutral	+\$0

Step 7. Attachment Bracket

1A	for Action Office® Series 1 and 2 radiused-edge work surface	+\$0
2A	for Action Office® Series 1 and 2 squared-edge work surface	+\$0
E1	for Ethospace® System	+\$0
F8	for Canvas Office Landscape®	+\$0

Step 8. Lock

KA	keyed alike	+\$0
KC	keyed differently, chrome	+\$0
KD	keyed differently, black	+\$0

W-Pull Support Pedestal *continued*

Step 9. Drawer Interior

For 20" deep (20) or 24" deep (24) with box/box/file (BBF)

NN	none	+\$0
2M	drawer divider in box drawers, 2 file converters in file drawer	+\$25
3M	drawer divider in one box drawer, pencil tray in one box drawer, 2 file converters in file drawer	+\$25
C51	storage organizer including hanging file holder bin, utility tray and two containers A	+\$120

For 28" deep (28) with box/box/file (BBF)

NN	none	+\$0
2M	drawer divider in box drawers, 2 file converters in file drawer	+\$25
3M	drawer divider in one box drawer, pencil tray in one box drawer, 2 file converters in file drawer	+\$25

For 20" deep (20) or 24" deep (24) with file/file (FF)

NN	none	+\$0
1M	2 file converters in each file drawer	+\$25
C51	storage organizer including hanging file holder bin, utility tray and two containers A	+\$120

For 28" deep (28) with file/file (FF)

NN	none	+\$0
1M	2 file converters in each file drawer	+\$25

V-Pull Support Pedestal

LV150.

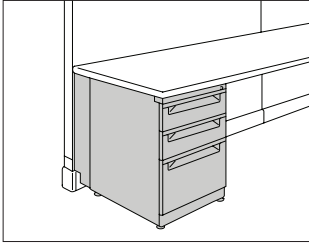

Tu® Metal Storage

Product Information

Description

This pedestal attaches to both a work surface and a panel or frame at either the end of a run or mid-run to provide support. It eliminates the need for a return panel/frame and connector or a work surface support panel. It has a smooth-steel case, full-width recessed pulls, and 1³/₄" leveling glides. It attaches under a work surface on the left or right side.

Attachment hardware and support bracket are included.

The actual pedestal depth is 19³/₈", 23¹/₄", or 27³/₄". A 20"-deep pedestal supports a 24"-deep work surface. A 24"-deep pedestal supports a 30"-deep Ethospace® work surface with cable management trough. A 28"-deep pedestal supports a 30"-deep work surface.

Drawers are available with full-extension or 3/4-extension slides. A drawer divider, utility tray or storage organizer is optional for box drawers. File drawers hold letter-size front-to-back hanging files. File converters are optional for letter-, legal-, and A4-size side-to-side hanging files.

Notes

Order optional accessories separately:

- Drawer divider (LG903.)
- File compressor (LG908)
- File converter (LG907)
- File drawer organizer (LG901)
- Pedestal stationery divider (LG905)
- Utility tray (LG906)
- Storage organizer (LG910)

Storage organizer includes a hanging file holder, utility tray (pencil tray) and 2 containers. The storage organizer frame color matches the drawer interior; file holder and containers are 91 white; utility tray is black.

For keyed-alike locks, order lock plugs separately. See Keyed-Alike Information in Appendices.

Dimensions

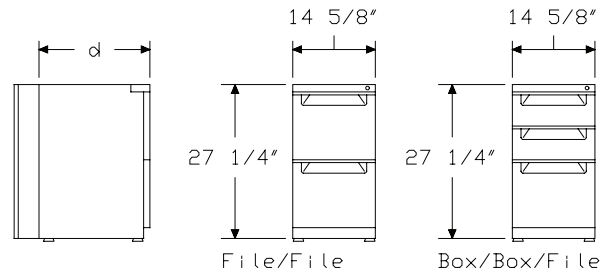

V-Pull Support Pedestal *continued*

Specification Information		
Step 1.		
LV150.		
Step 2. Depth		
20	20" deep	
24	24" deep	
28	28" deep	
Step 3. Configuration		
BBF	box/box/file	
FF	file/file	
Prices for Steps 1-3.		
		BBF FF
LV150. 20		\$594 551
24		\$622 592
28		\$656 626
Step 4. Slides		
<i>For box/box/file (BBF)</i>		
SR	¾-extension roller slides on box drawer, full-extension ball bearing on file drawer	+\$0
SB	full-extension ball-bearing	+\$50
<i>For file/file (FF)</i>		
SB	full-extension ball-bearing	+\$0
Step 5. Paint/Steel Type		
SS	smooth paint on smooth steel	+\$0
XS	textured paint on smooth steel	+\$0

Step 6. Surface Finish		
<i>For smooth paint on smooth steel (SS)</i>		
8Q	folkstone grey	+\$0
98	studio white	+\$0
BU	black umber	+\$0
CN	metallic champagne	+\$40
EH	metallic bronze	+\$40
HF	inner tone light	+\$0
LT	light tone	+\$0
LU	soft white	+\$0
MS	metallic silver	+\$40
MT	medium tone	+\$0
SG	slate grey	+\$0
WL	sandstone	+\$0
Sand Texture Paint		
<i>For textured paint on smooth steel (XS)</i>		
98	studio white	+\$0
Bright Sand Texture Paint		
<i>For textured paint on smooth steel (XS)</i>		
91	white	+\$0
CL	cool grey neutral	+\$0
G1	graphite	+\$0
WN	warm grey neutral	+\$0
Step 7. Attachment Bracket		
1A	for Action Office® Series 1 and 2 radiused-edge work surface	+\$0
2A	for Action Office® Series 1 and 2 squared-edge work surface	+\$0
E1	for Ethospace® System	+\$0
F8	for Canvas Office Landscape®	+\$0
Step 8. Lock		
KA	keyed alike	+\$0
KC	keyed differently, chrome	+\$0
KD	keyed differently, black	+\$0

V-Pull Support Pedestal *continued*

Tu® Metal Storage

Step 9. Drawer Interior

For 20" deep (20) or 24" deep (24) with box/box/file (BBF)

NN	none	+\$0
2M	drawer divider in box drawers, 2 file converters in file drawer	+\$25
3M	drawer divider in one box drawer, pencil tray in one box drawer, 2 file converters in file drawer	+\$25
C51	storage organizer including hanging file holder bin, utility tray and two containers A	+\$120

For 28" deep (28) with box/box/file (BBF)

NN	none	+\$0
2M	drawer divider in box drawers, 2 file converters in file drawer	+\$25
3M	drawer divider in one box drawer, pencil tray in one box drawer, 2 file converters in file drawer	+\$25

For 20" deep (20) or 24" deep (24) with file/file (FF)

NN	none	+\$0
1M	2 file converters in each file drawer	+\$25
C51	storage organizer including hanging file holder bin, utility tray and two containers A	+\$120

For 28" deep (28) with file/file (FF)

NN	none	+\$0
1M	2 file converters in each file drawer	+\$25

Bar Pull Suspended Pedestal

LK13A.
LK13D.

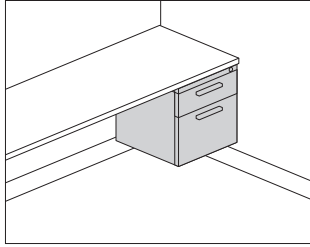

Product Information

Description

This pedestal mounts under a predrilled hanging or freestanding work surface. It has a smooth-steel case and applied metal bar pulls.

Mounting hardware included.

Actual pedestal depth is 19 3/8".

The box drawer is available with full-extension or 3/4-extension slides.

The file drawer has full-extension slides and holds letter-size front-to-back hanging files.

Notes

To add drawer divider, pencil tray, and file converters to drawer interiors, specify option (2M) or (3M).

For full extension slides on box drawer, specify option (SB).

Pedestal will not mount under the following products:

- Action Office® table
- Ethospace® peninsula with access
- Ethospace work surface in off-module application

Grain direction is vertical for veneer-front pedestals.

Order optional accessories separately:

- Drawer divider (LG903.)
- File compressor (LG908)
- File converter (LG907)
- File drawer organizer (LG901)
- Pedestal stationery divider (LG905)
- Utility tray (LG906)
- Storage organizer (LG910)

Storage organizer includes a hanging file holder, utility tray (pencil tray) and 2 containers. Storage organizer frame color matches drawer interior; file holder and containers are 91 white; utility tray is black.

For keyed-alike locks, order lock plugs separately. See Keyed-Alike Information in Appendices.

Dimensions

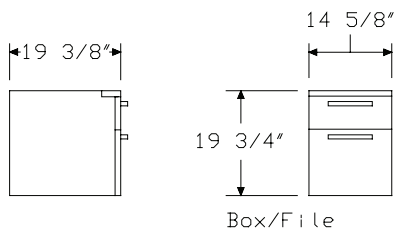

Specification Information

Step 1.

LK13

Step 2. Front Material

D.20BF painted metal front

A.20BF veneer front A

Prices for Steps 1-2.

LK13D.20BF \$466

LK13A.20BF \$642

Step 3. Slides

SR 3/4-extension roller slides on box drawer, full-extension ball bearing on file drawer +\$0

SB full-extension ball-bearing +\$25

Step 4. Paint/Steel Type

SS smooth paint on smooth steel +\$0

XS textured paint on smooth steel +\$0

Step 5. Surface Finish

For smooth paint on smooth steel (SS)

98 studio white +\$0

8Q folkstone grey +\$0

BU black umber +\$0

HF inner tone light +\$0

LT light tone +\$0

LU soft white +\$0

MT medium tone +\$0

SG slate grey +\$0

WL sandstone +\$0

CN metallic champagne +\$40

EH metallic bronze +\$40

MS metallic silver +\$40

Sand Texture Paint

For textured paint on smooth steel (XS)

98 studio white +\$0

Bright Sand Texture Paint

For textured paint on smooth steel (XS)

91 white +\$0

CL cool grey neutral +\$0

G1 graphite +\$0

WN warm grey neutral +\$0

Bar Pull Suspended Pedestal

continued

Tu® Metal Storage

Step 6. Front Finish For veneer front (A.2oBF)

Recut Veneer

RA	light ash <input type="checkbox"/>	+\$0
RK	mahogany dark <input type="checkbox"/>	+\$0
RM	mahogany <input type="checkbox"/>	+\$0

Wood Veneer

2U	light brown walnut <input type="checkbox"/>	+\$75
40	dark brown walnut <input type="checkbox"/>	+\$75
ED	aged cherry <input type="checkbox"/>	+\$75
EK	medium red walnut <input type="checkbox"/>	+\$75
EW	medium matte walnut <input type="checkbox"/>	+\$75
ET	clear on ash <input type="checkbox"/>	+\$75
EV	walnut on ash <input type="checkbox"/>	+\$75
UL	natural maple <input type="checkbox"/>	+\$75
UX	walnut on cherry <input type="checkbox"/>	+\$75

Step 7. Lock

KA	keyed alike	+\$0
KC	keyed differently, chrome	+\$0
KD	keyed differently, black	+\$0

Step 8. Pull Finish

8Q	folkstone grey	+\$0
91	white	+\$0
98	studio white	+\$0
G1	graphite <input type="checkbox"/>	+\$0
WL	sandstone <input type="checkbox"/>	+\$0
CN	metallic champagne <input type="checkbox"/>	+\$0
MS	metallic silver	+\$0
79	green apple <input type="checkbox"/>	+\$15
MY3	yellow oxide <input type="checkbox"/>	+\$15
RO	red <input type="checkbox"/>	+\$15
TRQ	turquoise <input type="checkbox"/>	+\$15

Step 9. Drawer Interior

NN	none	+\$0
4M	drawer divider in box drawer, 2 file converters in file drawer	+\$20
5M	pencil tray in box drawer, 2 file converters in file drawer	+\$20
C51	storage organizer including hanging file holder bin, utility tray and two containers <input type="checkbox"/>	+\$120

Arc Pull Suspended Pedestal

LQ13A.
LQ13D.

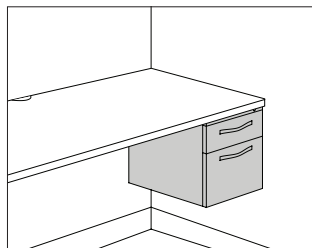

Product Information

Description

This pedestal mounts under a predrilled hanging or freestanding work surface. It has a smooth-steel case and applied metal arc pulls.

Mounting hardware included.

Actual pedestal depth is 19 3/8".

The box drawer is available with full-extension or 3/4-extension slides.

The file drawer has full-extension slides and holds letter-size front-to-back hanging files.

Notes

Pull design conforms to guidelines of Americans with Disabilities Act (ADA).

To add drawer divider, pencil tray, file converters and storage organizer to drawer interiors, specify option (4M), (5M) or (C51).

For full extension slides on box drawer, specify option (SB).

Pedestal will not mount under the following products:

- Action Office® table
- Ethospace® peninsula with access
- Ethospace work surface in off-module application

Grain direction is vertical for veneer-front pedestals.

Order optional accessories separately:

- Drawer divider (LG903.)
- File compressor (LG908)
- File converter (LG907)
- File drawer organizer (LG901)
- Pedestal stationery divider (LG905)
- Utility tray (LG906)
- Storage organizer (LG910)

Storage organizer includes a hanging file holder, utility tray (pencil tray) and 2 containers. The storage organizer frame color matches the drawer interior; file holder and containers are 91 white; utility tray is black.

For keyed-alike locks, order lock plugs separately. See Keyed-Alike

Information in Appendices.

Dimensions

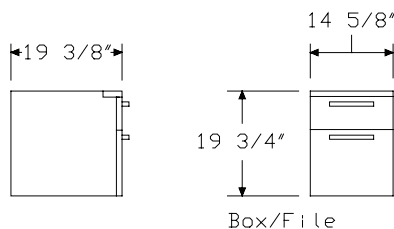

Arc Pull Suspended Pedestal

continued

Tu® Metal Storage

Specification Information

Step 1.

LQ13

Step 2. Front Material

D.20BF painted metal front

A.20BF veneer front A

Prices for Steps 1-2.

LQ13D.20BF \$466

LQ13A.20BF \$642

Step 3. Slides

SR ¾-extension roller slides on box drawer, full-extension ball bearing on file drawer +\$0

SB full-extension ball-bearing +\$25

Step 4. Paint/Steel Type

SS smooth paint on smooth steel +\$0

XS textured paint on smooth steel +\$0

Step 5. Surface Finish

For smooth paint on smooth steel (SS)

8Q folkstone grey +\$0

98 studio white +\$0

BU black umber +\$0

CN metallic champagne +\$40

EH metallic bronze +\$40

HF inner tone light +\$0

LT light tone +\$0

LU soft white +\$0

MS metallic silver +\$40

MT medium tone +\$0

SG slate grey +\$0

WL sandstone +\$0

Sand Texture Paint

For textured paint on smooth steel (XS)

98 studio white +\$0

Bright Sand Texture Paint

For textured paint on smooth steel (XS)

91 white +\$0

CL cool grey neutral +\$0

G1 graphite +\$0

WN warm grey neutral +\$0

Step 6. Front Finish

For veneer front (A.20BF)

Recut Veneer

RA light ash A +\$0

RK mahogany dark A +\$0

RM mahogany A +\$0

Wood Veneer

2U light brown walnut A +\$75

40 dark brown walnut A +\$75

ED aged cherry A +\$75

EK medium red walnut A +\$75

EW medium matte walnut A +\$75

ET clear on ash A +\$75

EU oak on ash A +\$75

EV walnut on ash A +\$75

UL natural maple A +\$75

UX walnut on cherry A +\$75

Step 7. Lock

KA keyed alike +\$0

KC keyed differently, chrome +\$0

KD keyed differently, black +\$0

Step 8. Pull Finish

NH brushed nickel +\$0

NK black nickel +\$0

Step 9. Drawer Interior

NN none +\$0

4M drawer divider in box drawer, 2 file converters in file drawer +\$20

5M pencil tray in box drawer, 2 file converters in file drawer +\$20

C51 storage organizer including hanging file holder bin, utility tray and two containers A +\$120

W-Pull Suspended Pedestal

LW130.

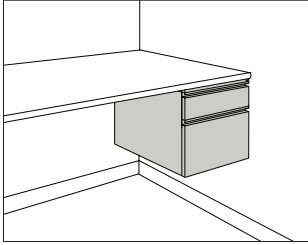

Product Information

Description

This pedestal mounts under a predrilled hanging or freestanding work surface. It has a smooth-steel case and full-width pulls. Mounting hardware included.

Actual pedestal depth is 19 3/8".

Drawers are available with full-extension or 3/4-extension slides. A drawer divider, utility tray or storage organizer is optional for box drawers. The file drawer holds letter-size front-to-back hanging files. File converters are optional for letter-, legal-, and A4-size side-to-side hanging files.

Notes

Pedestal will not mount under the following products:

- Action Office® table
- Ethospace® peninsula with access cover
- Ethospace work surface in off-module application

Order optional accessories separately:

- Drawer divider (LG903.)
- File compressor (LG908)
- File converter (LG907)
- File drawer organizer (LG901)
- Pedestal stationery divider (LG905)
- Utility tray (LG906)
- Storage organizer (LG910)

Storage organizer includes a hanging file holder, utility tray (pencil tray) and 2 containers. The storage organizer frame color matches the drawer interior; file holder and containers are 91 white; utility tray is black.

For keyed-alike locks, order lock plugs separately. See Keyed-Alike Information in Appendices.

Dimensions

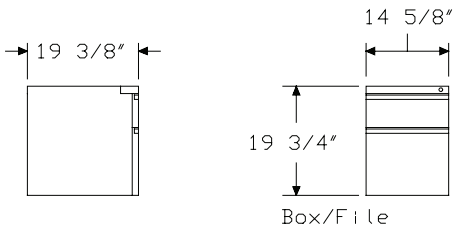

Specification Information

Step 1.

LW130.20BF \$379

Step 2. Slides

SR 3/4-extension roller slides on box drawer, full-extension ball bearing on file drawer +\$0

SB full-extension ball-bearing +\$25

Step 3. Paint/Steel Type

SS smooth paint on smooth steel +\$0

XS textured paint on smooth steel +\$0

Step 4. Surface Finish

For smooth paint on smooth steel (SS)

8Q folkstone grey +\$0

98 studio white +\$0

BU black umber +\$0

CN metallic champagne +\$40

EH metallic bronze +\$40

HF inner tone light +\$0

LT light tone +\$0

LU soft white +\$0

MS metallic silver +\$40

MT medium tone +\$0

SG slate grey +\$0

WL sandstone +\$0

Sand Texture Paint

For textured paint on smooth steel (XS)

98 studio white +\$0

Bright Sand Texture Paint

For textured paint on smooth steel (XS)

91 white +\$0

CL cool grey neutral +\$0

G1 graphite +\$0

WN warm grey neutral +\$0

W-Pull Suspended Pedestal

continued

Tu® Metal Storage

Step 5. Lock		
KA	keyed alike	+\$0
KC	keyed differently, chrome	+\$0
KD	keyed differently, black	+\$0

Step 6. Drawer Interior		
NN	none	+\$0
4M	drawer divider in box drawer, 2 file converters in file drawer	+\$20
5M	pencil tray in box drawer, 2 file converters in file drawer	+\$20
C51	storage organizer including hanging file holder bin, utility tray and two containers <input type="checkbox"/>	+\$120

V-Pull Suspended Pedestal

LV130.

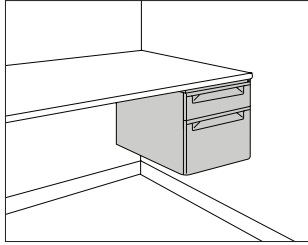

Product Information

Description

This pedestal mounts under a predrilled hanging or freestanding work surface. It has a smooth-steel case and full-width recessed pulls.

Mounting hardware included.

Actual pedestal depth is 19 3/8".

Drawers are available with full-extension or 3/4-extension slides. A drawer divider, utility tray or storage organizer is optional for box drawers. The file drawer holds letter-size front-to-back hanging files. File converters are optional for letter-, legal-, and A4-size side-to-side hanging files.

Notes

Pedestal will not mount under the following products:

- Action Office® table
- Ethospace® peninsula with access cover
- Ethospace work surface in off-module application

Order optional accessories separately:

- Drawer divider (LG903.)
- File compressor (LG908)
- File converter (LG907)
- File drawer organizer (LG901)
- Pedestal stationery divider (LG905)
- Utility tray (LG906)
- Storage organizer (LG910)

Storage organizer includes a hanging file holder, utility tray (pencil tray) and 2 containers. The storage organizer frame color matches the drawer interior; file holder and containers are 91 white; utility tray is black.

For keyed-alike locks, order lock plugs separately. See Keyed-Alike Information in Appendices.

Dimensions

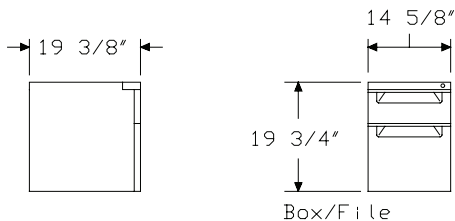

Specification Information

Step 1.

LV130.20BF \$408

Step 2. Slides

SR 3/4-extension roller slides on box drawer, full-extension ball bearing on file drawer +\$0

SB full-extension ball-bearing +\$25

Step 3. Paint/Steel Type

SS smooth paint on smooth steel +\$0

XS textured paint on smooth steel +\$0

Step 4. Surface Finish

For smooth paint on smooth steel (SS)

8Q folkstone grey +\$0

98 studio white +\$0

BU black umber +\$0

CN metallic champagne +\$40

EH metallic bronze +\$40

HF inner tone light +\$0

LT light tone +\$0

LU soft white +\$0

MS metallic silver +\$40

MT medium tone +\$0

SG slate grey +\$0

WL sandstone +\$0

Sand Texture Paint

For textured paint on smooth steel (XS)

98 studio white +\$0

Bright Sand Texture Paint

For textured paint on smooth steel (XS)

91 white +\$0

CL cool grey neutral +\$0

G1 graphite +\$0

WN warm grey neutral +\$0

V-Pull Suspended Pedestal *continued*

Tu® Metal Storage

Step 5. Lock

KA	keyed alike	+\$0
KC	keyed differently, chrome	+\$0
KD	keyed differently, black	+\$0

Step 6. Drawer Interior

NN	none	+\$0
4M	drawer divider in box drawer, 2 file converters in file drawer	+\$20
5M	pencil tray in box drawer, 2 file converters in file drawer	+\$20
C51	storage organizer including hanging file holder bin, utility tray and two containers <input type="checkbox"/>	+\$120

Pedestal Add-On Cushion Top

LG890.

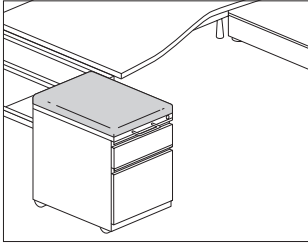

Product Information

Description

This 1"- or 2"-high cushion top is retrofit to a mobile pedestal with a flat metal top and provides temporary guest seating. Hook-and-loop fastener strips are included to attach cushion top to flat metal top.

Notes

Cushion top accepts Customer's Own Material (COM). Yardage is estimated for nondirectional, 54"-wide fabrics. Order 1/2 yard of fabric per cushion. For odd number of cushions, round up to next whole yard. For information on multiple quantities or directional fabrics, contact COM Department. See Order Information in Appendices.

Dimensions

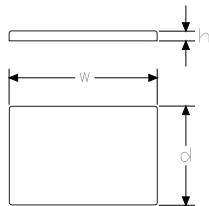

Specification Information

Step 1.

LG890.

Step 2. Height

- 1** 1" high
- 2** 2" high

Step 3. Depth

- 20** 20" deep
- 24** 24" deep

Prices for Steps 1-3.

	20	24
LG890. 1	\$128	159
2	\$151	190

Step 4. Cushion Top Fabric

See application chart and textiles list for fabric usage and numbers. First 2 digits of number indicate fabric line; remaining digit(s) indicate fabric color.

Price Category 1	+ \$0
Price Category 2	+ \$43
Price Category 3	+ \$61
Price Category 4	+ \$81
Price Category 7 A	+ \$147
Price Category 9	+ \$938
Price Category B	+ \$29
Price Category C	+ \$39
Price Category E	+ \$61
Price Category G	+ \$103
Price Category H	+ \$125

Storage Organizer

LG910.

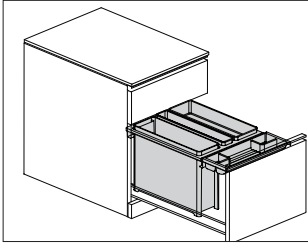

Tu® Metal Storage

Product Information

Description

This storage organizer includes 1 hanging file holder, 1 utility tray (pencil tray), and 2 containers. The storage organizer frame color matches the drawer interior. File holder and containers are 91 white, and the utility tray is black.

Notes

Storage organizer can be used in the following products:

- Tu® pedestals
- Tu storage towers

For 20" deep file drawer, storage organizer will include hanging file holder and 2 containers in 1 drawer, and utility tray in separate drawer.

For 24" deep drawer, utility tray can be placed inside the same drawer as the storage organizer unit.

Dimensions

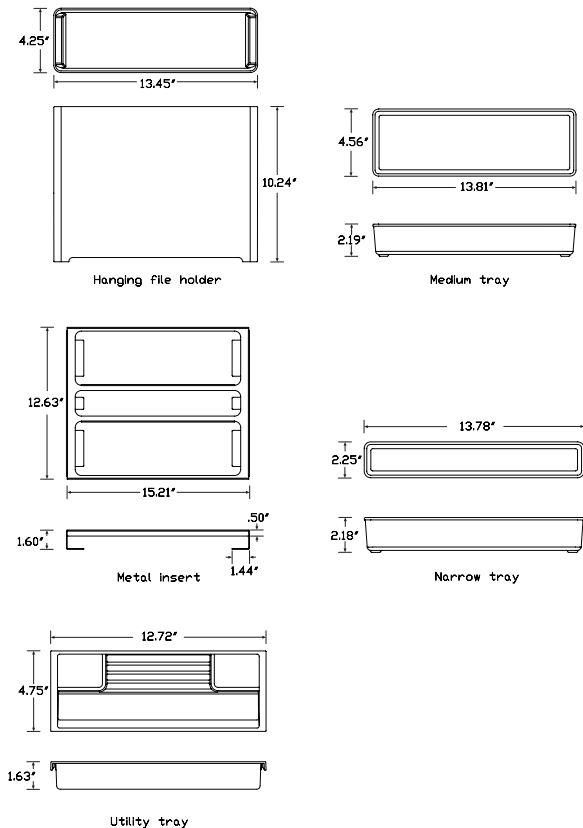

Specification Information

Step 1.

LG910. A

\$180

File Drawer Organizer

LG901

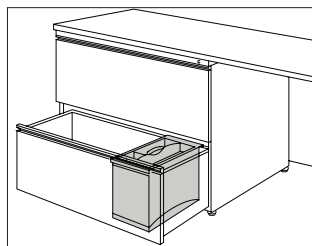

Product Information

Description

This 2-sectioned organizer fits into any file drawer arranged for letter-size filing. The removable top section stores computer disks and other small items. The bottom section stores larger items or can be divided into 3 compartments; it includes 2 vertical dividers. Finish is black umber.

Dimensions

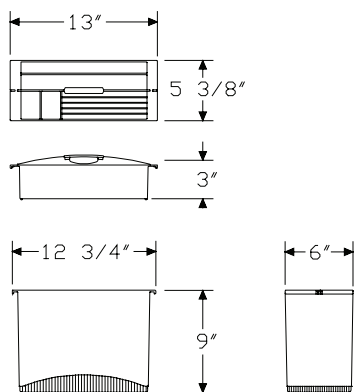

Specification Information

Step 1.

LG901

\$77

Drawer Divider, Tu® Pedestal

LG903.

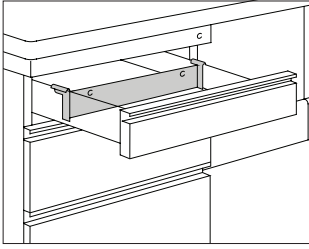

Tu® Metal Storage

Product Information

Description

This adjustable divider is used in a pencil or box drawer. Finish is black umber.

Notes

Divider can be used in the following products:

- 5000 Series furniture with B- and F-pull pedestals
- Tu® Q-, R-, T-, V-, and W-pull pedestals
- Tu storage towers

Dimensions

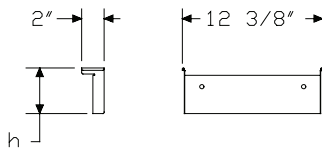

Specification Information

Step 1.

LG903.

Step 2. Usage

- 3** for pencil drawer
- 6** for box drawer

Prices for Steps 1-2.

LG903. 3	\$16
6	\$17

Stationery Divider, Tu® Pedestal LG905

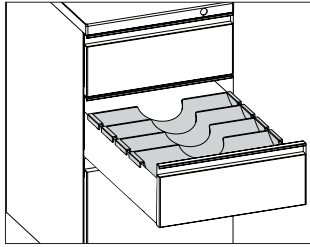

Product Information

Description

These 4 removable dividers are used in box drawers. Finish is black umber.

Notes

Dividers can be used in the following products:

- 5000 Series furniture with B- and F-pull pedestals
- Tu® Q-, R-, T-, V-, and W-pull pedestals
- Tu storage towers

Dimensions

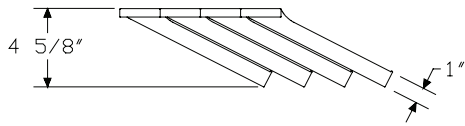

Specification Information

Step 1.

LG905

\$55

Utility Tray, Tu® Pedestal

LG906

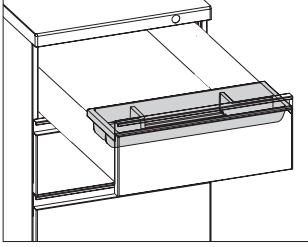

Tu® Metal Storage

Product Information

Description

This sectioned tray stores pencils and small items in a pencil or box drawer. Finish is black umber.

Notes

Tray can be used in the following products:

- 5000 Series furniture with B- and F-pull pedestals
- Tu® Q-, R-, T-, V-, and W-pull pedestals
- Tu storage towers

Dimensions

Specification Information

Step 1.

LG906

\$20

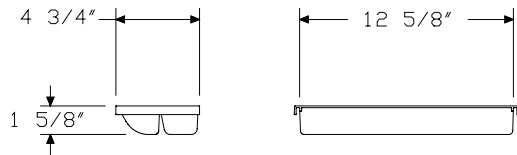

File Converter, Tu®

LG907

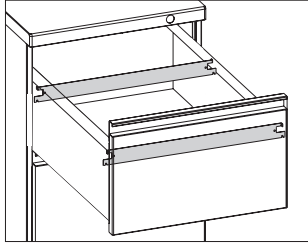

Product Information

Description

These black umber bars convert a file drawer to hold letter-, legal-, and A4-size side-to-side hanging files. 2 converters are used per drawer. Package contains 4.

Notes

- Converters can be used in the following products:
- 5000 Series furniture with B- and F-pull pedestals
 - Tu® Q-, R-, T-, V-, and W-pull pedestals
 - Tu storage towers

Dimensions

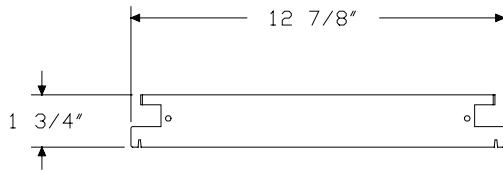

Specification Information

Step 1.

LG907

\$28

Tu® Metal Storage

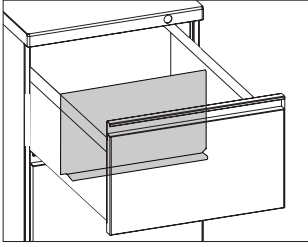

Tu® Metal Storage

Product Information

Description

These compressors lock into slots in the bottom of a pedestal file drawer to divide non-hanging files. Finish is black umber. Package contains 4.

Notes

Compressors can be used in the following products:

- 5000 Series furniture with B- and F-pull pedestals
- Tu® Q-, R-, T-, V-, and W-pull pedestals
- Tu storage towers

Dimensions

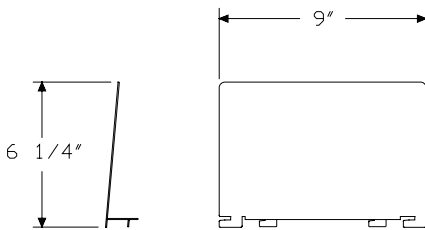

Specification Information

Step 1.

LG908

\$46

Bar-Pull Freestanding Lateral File LK20A.
LK20D.

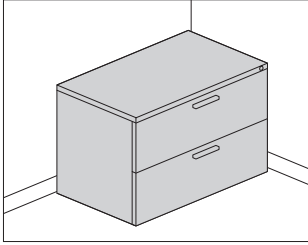

Product Information

Description

This lateral file has a painted or veneer front, smooth-steel case, and applied metal bar pulls. It includes 1" leveling glides and a positive interlock system that permits only 1 drawer or pullout shelf to open at a time. Drawers can be specified with side-to-side or front-to-back filing rails to accommodate letter-, legal-, and A4-size hanging files. The pullout shelf includes 3 file dividers.

Actual file depth is 19³/₈". Actual file width is 29⁵/₈", 35⁵/₈", or 41⁵/₈".

Interior height of the flipper door with pullout shelf is 10¹/₄". Raised-height configuration adds 1/2" to overall height to fill the space between the top of the file and the underside of a surface.

Notes

Base on 2 drawers, raised height option (1) aligns with base on Tu® storage towers.

2- or 3-high files that are not ganged or anchored require counterweights (option CB). When two 42"-wide, 4-high files are ganged side by side, each file requires a counterweight.

Counterweight specified with file is permanently installed. To order removable counterweight, specify file with no counterweight option (NO), and order counterweight (LG909.) separately.

Veneer-front lateral files have a vertical grain direction.

Order optional accessories separately:

- File drawer organizer (LG901)
- Front-to-back filing rail (LG904.)
- Movable divider (9M100) - For flipper door with pullout shelf only
- Side-to-side filing rail (LG902.)

For keyed-alike locks, order lock plugs separately. See Keyed-Alike Information in Appendices.

Dimensions

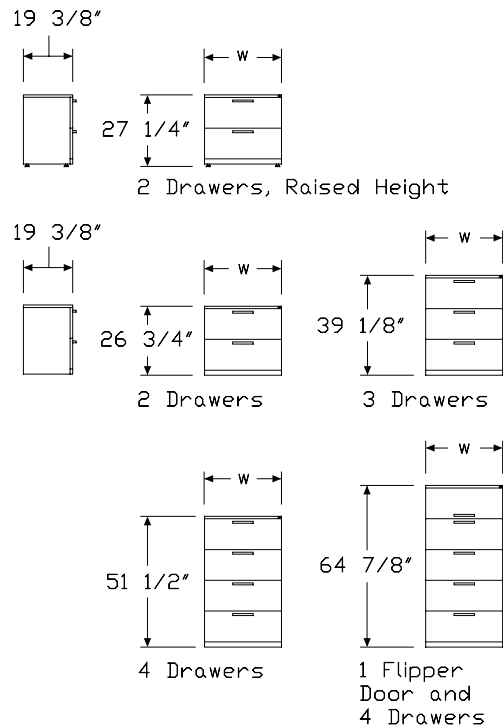

Bar-Pull Freestanding Lateral File

continued

Tu® Metal Storage

Specification Information

Step 1.

LK20

Step 2. Front Material

- D.** painted metal front
- A.** veneer front A

Step 3. Width

- 30** 30" wide
- 36** 36" wide
- 42** 42" wide

Step 4. Configuration

For painted metal front (D.)

- 1** 2 drawers, raised height
- 2** 2 drawers
- 3** 3 drawers
- 4** 4 drawers
- 5** 1 flipper door with pullout shelf and 4 drawers

For veneer front (A.)

- 1** 2 drawers, raised height
- 2** 2 drawers
- 3** 3 drawers
- 4** 4 drawers

Prices for Steps 1-4.

	1	2	3	4	5
LK20D. 30	\$1188	1188	1609	1925	2500
36	\$1243	1243	1658	2043	2593
42	\$1350	1350	1731	2148	2659
LK20A. 30	\$1550	1550	2105	2548	—
36	\$1607	1607	2154	2670	—
42	\$1719	1719	2231	2780	—

Step 5. Paint/Steel Type

- SS** smooth paint on smooth steel +\$0
- XS** textured paint on smooth steel +\$0

Step 6. Surface Finish

For smooth paint on smooth steel (SS)

- 8Q** folkstone grey +\$0
- 98** studio white +\$0
- BU** black umber +\$0
- CN** metallic champagne +\$65
- EH** metallic bronze +\$65
- HF** inner tone light +\$0
- LT** light tone +\$0
- LU** soft white +\$0
- MS** metallic silver +\$65
- MT** medium tone +\$0
- SG** slate grey +\$0
- WL** sandstone +\$0

Sand Texture Paint

For textured paint on smooth steel (XS)

- 98** studio white +\$0

Bright Sand Texture Paint

For textured paint on smooth steel (XS)

- 91** white +\$0
- CL** cool grey neutral +\$0
- G1** graphite +\$0
- WN** warm grey neutral +\$0

Step 7. Front Finish

Recut Veneer

For 2 drawers, raised height (1) or 2 drawers (2)

- RA** light ash A +\$0
- RK** mahogany dark A +\$0
- RM** mahogany A +\$0

Wood Veneer

For 2 drawers, raised height (1) or 2 drawers (2)

- 2U** light brown walnut A +\$74
- 40** dark brown walnut A +\$74
- ED** aged cherry A +\$74
- EK** medium red walnut A +\$74
- EW** medium matte walnut A +\$74
- ET** clear on ash A +\$74
- EV** walnut on ash A +\$74
- UL** natural maple A +\$74
- UX** walnut on cherry A +\$74

Bar-Pull Freestanding Lateral File

continued

Recut Veneer		
<i>For 3 drawers (3)</i>		
RA	light ash <input type="checkbox"/>	+\$0
RK	mahogany dark <input type="checkbox"/>	+\$0
RM	mahogany <input type="checkbox"/>	+\$0

Wood Veneer		
<i>For 3 drawers (3)</i>		
2U	light brown walnut <input type="checkbox"/>	+\$114
40	dark brown walnut <input type="checkbox"/>	+\$114
ED	aged cherry <input type="checkbox"/>	+\$114
EK	medium red walnut <input type="checkbox"/>	+\$114
EW	medium matte walnut <input type="checkbox"/>	+\$114
ET	clear on ash <input type="checkbox"/>	+\$114
EV	walnut on ash <input type="checkbox"/>	+\$114
UL	natural maple <input type="checkbox"/>	+\$114
UX	walnut on cherry <input type="checkbox"/>	+\$114

Recut Veneer		
<i>For 4 drawers (4)</i>		
RA	light ash <input type="checkbox"/>	+\$0
RK	mahogany dark <input type="checkbox"/>	+\$0
RM	mahogany <input type="checkbox"/>	+\$0

Wood Veneer		
<i>For 4 drawers (4)</i>		
2U	light brown walnut <input type="checkbox"/>	+\$154
40	dark brown walnut <input type="checkbox"/>	+\$154
ED	aged cherry <input type="checkbox"/>	+\$154
EK	medium red walnut <input type="checkbox"/>	+\$154
EW	medium matte walnut <input type="checkbox"/>	+\$154
ET	clear on ash <input type="checkbox"/>	+\$154
EV	walnut on ash <input type="checkbox"/>	+\$154
UL	natural maple <input type="checkbox"/>	+\$154
UX	walnut on cherry <input type="checkbox"/>	+\$154

Step 8. Lock		
KA	keyed alike	+\$0
KC	keyed differently, chrome	+\$0
KD	keyed differently, black	+\$0

Step 9. Pull Finish		
8Q	folkstone grey	+\$0
91	white	+\$0
98	studio white	+\$0
G1	graphite <input type="checkbox"/>	+\$0
WL	sandstone <input type="checkbox"/>	+\$0
CN	metallic champagne <input type="checkbox"/>	+\$0
MS	metallic silver	+\$0
79	green apple <input type="checkbox"/>	+\$15
MY3	yellow oxide <input type="checkbox"/>	+\$15
RO	red <input type="checkbox"/>	+\$15
TRQ	turquoise <input type="checkbox"/>	+\$15

Step 10. Counterweight				
		30	36	42
NO	no counterweight (must gang or anchor)	+\$0	0	0
CB	counterweight (recommended)	+\$50	95	95

Step 11. Drawer Interior		
<i>For 2 drawers, raised height (1), 2 drawers (2), 3 drawers (3), or 4 drawers (4)</i>		
1R	front-to-back filing rail	+\$0
2R	side-to-side filing rail	+\$0

<i>For 1 flipper door with pullout shelf and 4 drawers (5)</i>		
3R	front-to-back filing rail and dividers in flipper	+\$0
4R	side-to-side filing rail and dividers in flipper	+\$0

Arc Pull Freestanding Lateral File

LQ20A.
LQ20D.

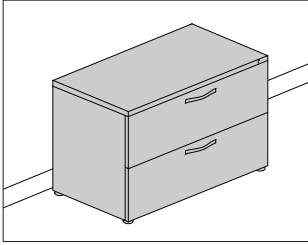

Tu® Metal Storage

Product Information

Description

This lateral file has a painted or veneer front, smooth-steel case, and applied metal arc pulls. It includes 1" leveling glides and a positive interlock system that permits only 1 drawer or pullout shelf to open at a time. Drawers can be specified with side-to-side or front-to-back filing rails to accommodate letter-, legal-, and A4-size hanging files. The pullout shelf includes 3 file dividers.

Actual file depth is 19³/₈". Actual file width is 29⁵/₈", 35⁵/₈", or 41⁵/₈".

Interior height of the flipper door with pullout shelf is 10¹/₄". Raised-height configuration adds 1/2" to overall height to fill the space between the top of the file and the underside of a surface.

Notes

Pull design conforms to guidelines of Americans with Disabilities Act (ADA).

Base and pull heights on 2 drawers, raised height option (1) align with arc pull Tu® storage towers.

2- or 3-high files that are not ganged or anchored require counterweights (option CB). When two 42"-wide, 4-high files are ganged side by side, each file requires a counterweight.

Counterweight specified with file is permanently installed. To order removable counterweight, specify file with no counterweight (option NO), and order counterweight (LG909) separately.

Accepts Tu® add-on cushion top (LG891).

Veneer-front lateral files have a vertical grain direction.

Order optional accessories separately:

- File drawer organizer (LG901)
- Front-to-back filing rail (LG904.)
- Movable divider (9M100) - For flipper door with pullout shelf only
- Side-to-side filing rail (LG902.)

For keyed-alike locks, order lock plugs separately. See Keyed-Alike Information in Appendices.

Dimensions

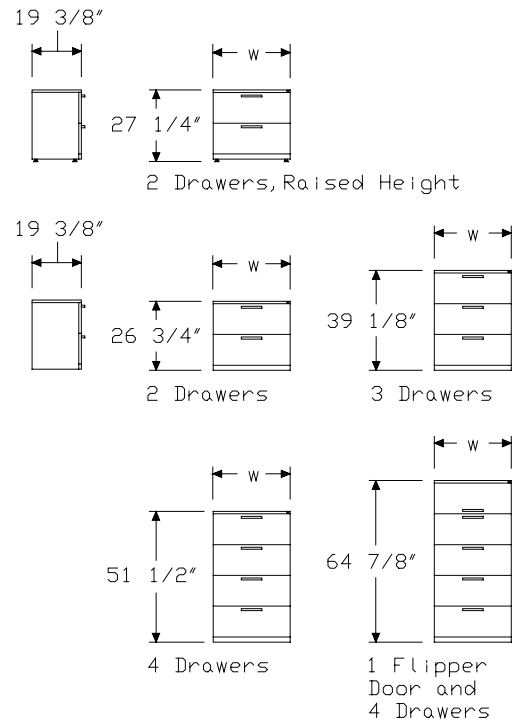

Arc Pull Freestanding Lateral File

continued

Specification Information

Step 1.

LQ20

Step 2. Front Material

- D.** painted metal front
- A.** veneer front A

Step 3. Width

- 30** 30" wide
- 36** 36" wide
- 42** 42" wide

Step 4. Configuration

For painted metal front (D.)

- 1** 2 drawers, raised height
- 2** 2 drawers
- 3** 3 drawers
- 4** 4 drawers
- 5** 1 flipper door with pullout shelf and 4 drawers

For veneer front (A.)

- 1** 2 drawers, raised height
- 2** 2 drawers
- 3** 3 drawers
- 4** 4 drawers

Prices for Steps 1-4.

	1	2	3	4	5
LQ20D. 30	\$1188	1188	1609	1925	2500
36	\$1243	1243	1658	2043	2593
42	\$1350	1350	1731	2148	2659
LQ20A. 30	\$1550	1550	2105	2548	—
36	\$1607	1607	2154	2670	—
42	\$1719	1719	2231	2780	—

Step 5. Paint/Steel Type

- SS** smooth paint on smooth steel +\$0
- XS** textured paint on smooth steel +\$0

Step 6. Surface Finish

For smooth paint on smooth steel (SS)

- 8Q** folkstone grey +\$0
- 98** studio white +\$0
- BU** black umber +\$0
- CN** metallic champagne +\$65
- EH** metallic bronze +\$65
- HF** inner tone light +\$0
- LT** light tone +\$0
- LU** soft white +\$0
- MS** metallic silver +\$65
- MT** medium tone +\$0
- SG** slate grey +\$0
- WL** sandstone +\$0

Sand Texture Paint

For textured paint on smooth steel (XS)

- 98** studio white +\$0

Bright Sand Texture Paint

For textured paint on smooth steel (XS)

- 91** white +\$0
- CL** cool grey neutral +\$0
- G1** graphite +\$0
- WN** warm grey neutral +\$0

Step 7. Front Finish

Recut Veneer

For veneer front (A.) with 2 drawers, raised height (1), or 2 drawers (2)

- RA** light ash A +\$0
- RK** mahogany dark A +\$0
- RM** mahogany A +\$0

Wood Veneer

For veneer front (A.) with 2 drawers, raised height (1), or 2 drawers (2)

- 2U** light brown walnut A +\$74
- 40** dark brown walnut A +\$74
- ED** aged cherry A +\$74
- EK** medium red walnut A +\$74
- EW** medium matte walnut A +\$74
- ET** clear on ash A +\$74
- EU** oak on ash A +\$74
- EV** walnut on ash A +\$74
- UL** natural maple A +\$74
- UX** walnut on cherry A +\$74

Arc Pull Freestanding Lateral File

continued

Tu® Metal Storage

Recut Veneer

For veneer front (A.) with 3 drawers (3)

RA	light ash <input type="checkbox"/>	+\$0
RK	mahogany dark <input type="checkbox"/>	+\$0
RM	mahogany <input type="checkbox"/>	+\$0

Wood Veneer

For veneer front (A.) with 3 drawers (3)

2U	light brown walnut <input type="checkbox"/>	+\$114
40	dark brown walnut <input type="checkbox"/>	+\$114
ED	aged cherry <input type="checkbox"/>	+\$114
EK	medium red walnut <input type="checkbox"/>	+\$114
EW	medium matte walnut <input type="checkbox"/>	+\$114
ET	clear on ash <input type="checkbox"/>	+\$114
EU	oak on ash <input type="checkbox"/>	+\$114
EV	walnut on ash <input type="checkbox"/>	+\$114
UL	natural maple <input type="checkbox"/>	+\$114
UX	walnut on cherry <input type="checkbox"/>	+\$114

Recut Veneer

For veneer front (A.) with 4 drawers (4)

RA	light ash <input type="checkbox"/>	+\$0
RK	mahogany dark <input type="checkbox"/>	+\$0
RM	mahogany <input type="checkbox"/>	+\$0

Wood Veneer

For veneer front (A.) with 4 drawers (4)

2U	light brown walnut <input type="checkbox"/>	+\$154
40	dark brown walnut <input type="checkbox"/>	+\$154
ED	aged cherry <input type="checkbox"/>	+\$154
EK	medium red walnut <input type="checkbox"/>	+\$154
EW	medium matte walnut <input type="checkbox"/>	+\$154
ET	clear on ash <input type="checkbox"/>	+\$154
EU	oak on ash <input type="checkbox"/>	+\$154
EV	walnut on ash <input type="checkbox"/>	+\$154
UL	natural maple <input type="checkbox"/>	+\$154
UX	walnut on cherry <input type="checkbox"/>	+\$154

Step 8. Lock

KA	keyed alike	+\$0
KC	keyed differently, chrome	+\$0
KD	keyed differently, black	+\$0

Step 9. Pull Finish

NH	brushed nickel	+\$0
NK	black nickel	+\$0

Step 10. Counterweight

		30	36	42
NO	no counterweight (must gang or anchor)	+\$0	0	0
CB	counterweight (recommended)	+\$50	95	95

Step 11. Drawer Interior

For 2 drawers, raised height (1), 2 drawers (2), 3 drawers (3), or 4 drawers (4)

1R	front-to-back filing rail	+\$0
2R	side-to-side filing rail	+\$0

For 1 flipper door with pullout shelf and 4 drawers (5)

3R	front-to-back filing rail and dividers in flipper	+\$0
4R	side-to-side filing rail and dividers in flipper	+\$0

W-Pull Freestanding Lateral File LW200.

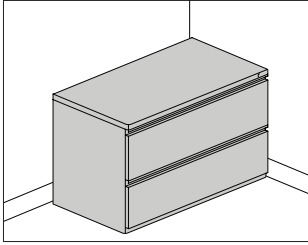

Product Information

Description

This lateral file has a smooth-steel case and full-width, integrated pulls. It includes 1" leveling glides and a positive interlock system that permits only 1 drawer or pullout shelf to open at a time. Drawers can be specified with side-to-side or front-to-back filing rails to accommodate letter-, legal-, and A4-size hanging files. The pullout shelf includes 3 dividers.

Actual file depth is 19³/₈". Actual file width is 29⁵/₈", 35⁵/₈", or 41⁵/₈". Interior height of the flipper door with pullout shelf is 10¹/₄". Raised-height configuration adds 1/2" to the overall height to fill the space between the top of the file and the underside of a surface.

Notes

Base on 2 drawers, raised height option (1) aligns with base on Tu® storage towers.

2- or 3-high files that are not ganged or anchored require counterweights (option CB). When two 42"-wide, 4-high files are ganged side by side, each file requires a counterweight.

Counterweight specified with file is permanently installed. To order removable counterweight, specify file with no counterweight (option NO), and order counterweight (LG909.) separately.

Accepts Tu® add-on cushion top (LG891.).

Order optional accessories separately:

- File drawer organizer (LG901)
- Front-to-back filing rail (LG904.)
- Movable divider (9M100) - For flipper door with pullout shelf only
- Side-to-side filing rail (LG902.)

For keyed-alike locks, order lock plugs separately. See Keyed-Alike Information in Appendices.

Dimensions

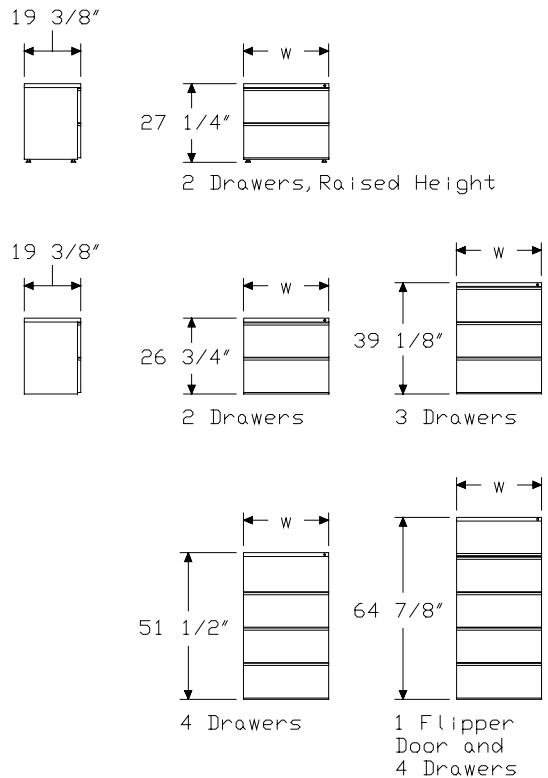

W-Pull Freestanding Lateral File

continued

Tu® Metal Storage

Specification Information

Step 1.

LW200.

Step 2. Width

30	30" wide
36	36" wide
42	42" wide

Step 3. Configuration

1	2 drawers, raised height
2	2 drawers
3	3 drawers
4	4 drawers
5	1 flipper door with pullout shelf and 4 drawers

Prices for Steps 1-3.

	1	2	3	4	5
LW200.30	\$866	866	1135	1400	1970
36	\$957	957	1252	1540	2121
42	\$1051	1051	1367	1679	2327

Step 4. Paint/Steel Type

SS	smooth paint on smooth steel	+\$0
XS	textured paint on smooth steel	+\$0

Step 5. Surface Finish

For smooth paint on smooth steel (SS)

8Q	folkstone grey	+\$0
98	studio white	+\$0
BU	black umber	+\$0
CN	metallic champagne	+\$65
EH	metallic bronze	+\$65
HF	inner tone light	+\$0
LT	light tone	+\$0
LU	soft white	+\$0
MS	metallic silver	+\$65
MT	medium tone	+\$0
SG	slate grey	+\$0
WL	sandstone	+\$0

Sand Texture Paint

For textured paint on smooth steel (XS)

98	studio white	+\$0
-----------	--------------	------

Bright Sand Texture Paint

For textured paint on smooth steel (XS)

91	white	+\$0
CL	cool grey neutral	+\$0
G1	graphite	+\$0
WN	warm grey neutral	+\$0

Step 6. Lock

KA	keyed alike	+\$0
KC	keyed differently, chrome	+\$0
KD	keyed differently, black	+\$0

Step 7. Counterweight

	30	36	42	
NO	no counterweight (must gang or anchor)	+\$0	0	0
CB	counterweight (recommended)	+\$50	95	95

Step 8. Drawer Interior

For 2 drawers, raised height (1) or 2 drawers (2)

2R	side-to-side filing rail	+\$0
1R	front-to-back filing rail	+\$35

For 3 drawers (3)

2R	side-to-side filing rail	+\$0
1R	front-to-back filing rail	+\$50

For 4 drawers (4)

2R	side-to-side filing rail	+\$0
1R	front-to-back filing rail	+\$65

For 1 flipper door with pullout shelf and 4 drawers (5)

4R	side-to-side filing rail and dividers in flipper	+\$0
3R	front-to-back filing rail and dividers in flipper	+\$80

W-Pull Lateral File, with Open Shelf

LW260.

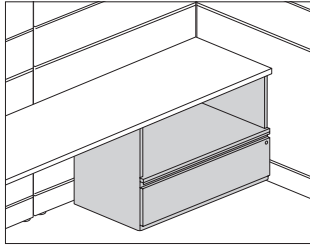

Product Information

Description

This lateral file attaches below a surface and has a file drawer in the lower section with an open shelf above and no finished top. It has a smooth-steel case and recessed base with 1" leveling glides. The drawer has a full-width, integrated pull, and can be specified with side-to-side or front-to-back filing rails to accommodate letter-, legal-, and A4-size hanging files. The open shelf accommodates 12" binders.

Actual file depth is 19³/₈". Actual file width is 29⁵/₈", 35⁵/₈", or 41⁵/₈".

Interior shelf width is 27³/₄", 33³/₄", or 39³/₄".

Notes

Lateral file attaches to a 24"-deep surface only.

When lateral file is attached to a surface, a counterweight is not required.

When lateral file is attached to a surface, the surface height is 28¹/₂".

Counterweight specified with file is permanently installed. To order removable counterweight, specify file with no counterweight (option NO), and order counterweight (LG909.) separately.

Order optional accessories separately:

- File drawer organizer (LG901)
- Front-to-back filing rail (LG904.)
- Side-to-side filing rail (LG902.)
- Storage case shelf (LG940.)

For keyed-alike locks, order lock plugs separately. See Keyed-Alike Information in Appendices.

Dimensions

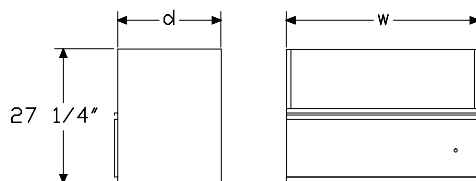

Specification Information

Step 1.

LW260.

Step 2. Width

30	30" wide
36	36" wide
42	42" wide

Prices for Steps 1-2.

LW260. 30	\$851
36	\$944
42	\$1041

Step 3. Paint/Steel Type

SS	smooth paint on smooth steel	+\$0
XS	textured paint on smooth steel	+\$0

Step 4. Surface Finish

For smooth paint on smooth steel (SS)

8Q	folkstone grey	+\$0
98	studio white	+\$0
BU	black umber	+\$0
CN	metallic champagne	+\$65
EH	metallic bronze	+\$65
HF	inner tone light	+\$0
LT	light tone	+\$0
LU	soft white	+\$0
MS	metallic silver	+\$65
MT	medium tone	+\$0
SG	slate grey	+\$0
WL	sandstone	+\$0

Sand Texture Paint

For textured paint on smooth steel (XS)

98	studio white	+\$0
-----------	--------------	------

Bright Sand Texture Paint

For textured paint on smooth steel (XS)

91	white	+\$0
CL	cool grey neutral	+\$0
G1	graphite	+\$0
WN	warm grey neutral	+\$0

W-Pull Lateral File, with Open Shelf *continued*

Tu® Metal Storage

Step 5. Lock

KA	keyed alike				+\$0
KC	keyed differently, chrome				+\$0
KD	keyed differently, black				+\$0

Step 6. Counterweight

		30	36	42	
NO	no counterweight (must gang or anchor)	+\$0	0	0	
CB	counterweight	+\$25	48	48	

Step 7. Drawer Interior

2R	side-to-side filing rail				+\$0
1R	front-to-back filing rail				+\$17

V-Pull Freestanding Lateral File

LV200.

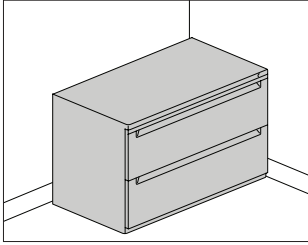

Product Information

Description

This lateral file has a smooth-steel case and full-width, recessed pulls. It includes 1" leveling glides and a positive interlock system that permits only 1 drawer or pullout shelf to open at a time. Drawers can be specified with side-to-side or front-to-back filing rails to accommodate letter-, legal-, and A4-size hanging files. The pullout shelf includes 3 file dividers.

Actual file depth is 19³/₈". Actual file width is 29⁵/₈", 35⁵/₈", or 41⁵/₈".

Interior height of the flipper door with pullout shelf is 10¹/₄". Raised-height configuration adds 1/2" to overall height to fill the space between the top of the file and the underside of a surface.

Notes

Base on 2 drawers, raised height option (1) aligns with base on Tu® storage towers.

2- or 3-high files that are not ganged or anchored require counterweights (option CB). When two 42"-wide, 4-high files are ganged side by side, each file requires a counterweight.

Counterweight specified with file is permanently installed. To order removable counterweight, specify file with no counterweight (option NO), and order counterweight (LG909.) separately.

Accepts Tu® add-on cushion top (LG891.).

Order optional accessories separately:

- File drawer organizer (LG901)
- Front-to-back filing rail (LG904.)
- Movable divider (9M100) - For flipper door with pullout shelf only
- Side-to-side filing rail (LG902.)

For keyed-alike locks, order lock plugs separately. See Keyed-Alike Information in Appendices.

Dimensions

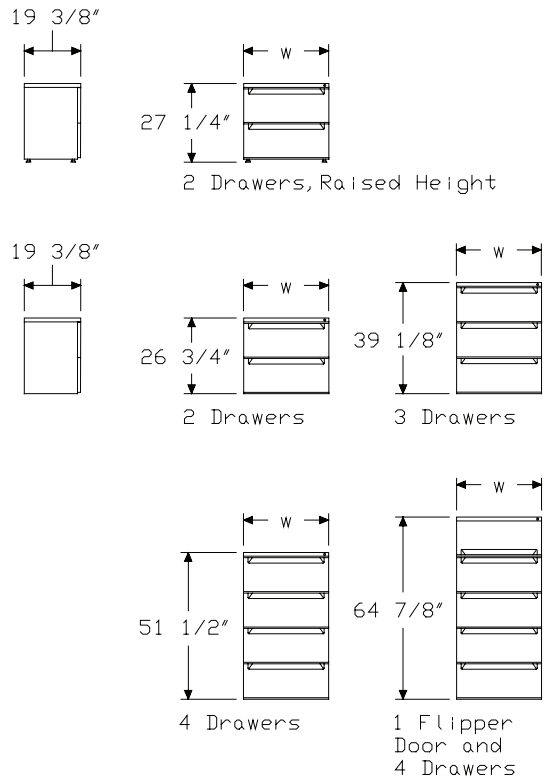

V-Pull Freestanding Lateral File

continued

Tu® Metal Storage

Specification Information

Step 1.

LV200.

Step 2. Width

30	30" wide
36	36" wide
42	42" wide

Step 3. Configuration

1	2 drawers, raised height
2	2 drawers
3	3 drawers
4	4 drawers
5	1 flipper door with pullout shelf and 4 drawers

Prices for Steps 1-3.

	1	2	3	4	5
LV200. 30	\$872	872	1145	1446	1963
36	\$970	970	1264	1593	2114
42	\$1062	1062	1383	1737	2317

Step 4. Paint/Steel Type

SS	smooth paint on smooth steel	+\$0
XS	textured paint on smooth steel	+\$0

Step 5. Surface Finish

For smooth paint on smooth steel (SS)

8Q	folkstone grey	+\$0
98	studio white	+\$0
BU	black umber	+\$0
CN	metallic champagne	+\$65
EH	metallic bronze	+\$65
HF	inner tone light	+\$0
LT	light tone	+\$0
LU	soft white	+\$0
MS	metallic silver	+\$65
MT	medium tone	+\$0
SG	slate grey	+\$0
WL	sandstone	+\$0

Sand Texture Paint

For textured paint on smooth steel (XS)

98	studio white	+\$0
-----------	--------------	------

Bright Sand Texture Paint

For textured paint on smooth steel (XS)

91	white	+\$0
CL	cool grey neutral	+\$0
G1	graphite	+\$0
WN	warm grey neutral	+\$0

Step 6. Lock

KA	keyed alike	+\$0
KC	keyed differently, chrome	+\$0
KD	keyed differently, black	+\$0

Step 7. Counterweight

	30	36	42	
NO	no counterweight (must gang or anchor)	+\$0	0	0
CB	counterweight (recommended)	+\$50	95	95

Step 8. Drawer Interior

For 2 drawers, raised height (1) or 2 drawers (2)

2R	side-to-side filing rail	+\$0
1R	front-to-back filing rail	+\$35

For 3 drawers (3)

2R	side-to-side filing rail	+\$0
1R	front-to-back filing rail	+\$50

For 4 drawers (4)

2R	side-to-side filing rail	+\$0
1R	front-to-back filing rail	+\$65

For 1 flipper door with pullout shelf and 4 drawers (5)

4R	side-to-side filing rail and dividers in flipper	+\$0
3R	front-to-back filing rail and dividers in flipper	+\$80

V-Pull Lateral File, with Open Shelf

LV260.

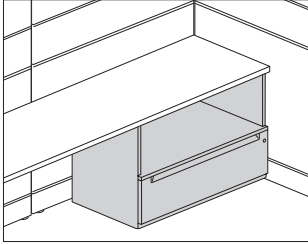

Product Information

Description

This lateral file attaches below a surface and has a file drawer in the lower section with an open shelf above and no finished top. It has a smooth-steel case and recessed base with 1" leveling glides. The drawer has a full-width, recessed pull, and can be specified with side-to-side or front-to-back filing rails to accommodate letter-, legal-, and A4-size hanging files. The open shelf accommodates 12" binders.

Actual file depth is 19³/₈". Actual file width is 29⁵/₈", 35⁵/₈", or 41⁵/₈".

Interior shelf width is 27³/₄", 33³/₄", or 39³/₄".

Notes

Lateral file attaches to a 24"-deep surface only.

When lateral file is attached to a surface, a counterweight is not required.

When lateral file is attached to a surface, the surface height is 28¹/₂".

Counterweight specified with file is permanently installed. To order removable counterweight, specify file with no counterweight (option NO), and order counterweight (LG909.) separately.

Order optional accessories separately:

- File drawer organizer (LG901)
- Front-to-back filing rail (LG904.)
- Side-to-side filing rail (LG902.)
- Storage case shelf (LG940.)

For keyed-alike locks, order lock plugs separately. See Keyed-Alike Information in Appendices.

Dimensions

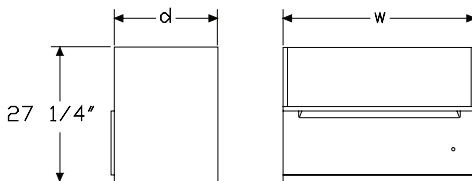

Specification Information

Step 1.

LV260.

Step 2. Width

30	30" wide
36	36" wide
42	42" wide

Prices for Steps 1-2.

LV260. 30	\$885
36	\$982
42	\$1079

Step 3. Paint/Steel Type

SS	smooth paint on smooth steel	+\$0
XS	textured paint on smooth steel	+\$0

Step 4. Surface Finish

For smooth paint on smooth steel (SS)

8Q	folkstone grey	+\$0
98	studio white	+\$0
BU	black umber	+\$0
CN	metallic champagne	+\$65
EH	metallic bronze	+\$65
HF	inner tone light	+\$0
LT	light tone	+\$0
LU	soft white	+\$0
MS	metallic silver	+\$65
MT	medium tone	+\$0
SG	slate grey	+\$0
WL	sandstone	+\$0

Sand Texture Paint

For textured paint on smooth steel (XS)

98	studio white	+\$0
-----------	--------------	------

Bright Sand Texture Paint

For textured paint on smooth steel (XS)

91	white	+\$0
CL	cool grey neutral	+\$0
G1	graphite	+\$0
WN	warm grey neutral	+\$0

V-Pull Lateral File, with Open Shelf *continued*

Tu® Metal Storage

Step 5. Lock				
KA	keyed alike			+\$0
KC	keyed differently, chrome			+\$0
KD	keyed differently, black			+\$0

Step 6. Counterweight		30	36	42
NO	no counterweight (must gang or anchor)	+\$0	0	0
CB	counterweight	+\$25	48	48

Step 7. Drawer Interior				
2R	side-to-side filing rail			+\$0
1R	front-to-back filing rail			+\$17

Bar-Pull Add-On Overfile

LK410D
LK410L

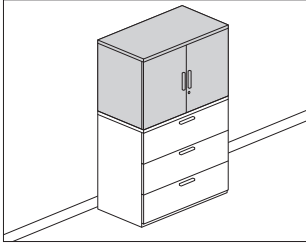

Product Information

Description

This overfile is field installed to the top of a Tu® lateral file. It has hinged doors that open to 110°, a painted front, smooth-steel case and applied metal bar pull. File includes 1 shelf that is binder adjustable. Mounting hardware included.

Actual height is 26¹/₈". Actual depth is 19³/₈". Actual width is 29⁷/₈", 35⁵/₈", or 41⁵/₈" to mount to same-width lateral file.

Notes

Overfile can only be mounted to top of 2-, 3-, or 4-drawer Tu lateral file.

Attachment of overfile requires drilling through top of lateral file.

Not available with veneer front.

For best aesthetics, mount overfile to Q-pull lateral file.

Dimensions

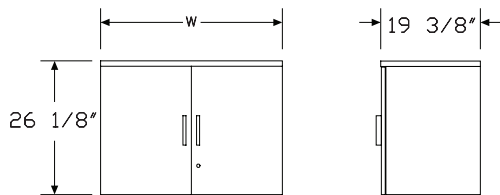

Specification Information

Step 1.

LK410

Step 2. Front Material

- D.** painted metal front
- L.** laminate front

Step 3. Width

- 30** 30" wide
- 36** 36" wide
- 42** 42" wide

Prices for Steps 1-3.

LK410D.	30	\$945
	36	\$1067
	42	\$1209
LK410L.	30	\$1087
	36	\$1227
	42	\$1390

Step 4. Paint/Steel Type

- SS** smooth paint on smooth steel +\$0
- XS** textured paint on smooth steel +\$0

Step 5. Surface Finish

For smooth paint on smooth steel (SS)

- 8Q** folkstone grey +\$0
- 98** studio white +\$0
- BU** black umber +\$0
- CN** metallic champagne +\$65
- EH** metallic bronze +\$65
- HF** inner tone light +\$0
- LT** light tone +\$0
- LU** soft white +\$0
- MS** metallic silver +\$65
- MT** medium tone +\$0
- SG** slate grey +\$0
- WL** sandstone +\$0

Sand Texture Paint

For textured paint on smooth steel (XS)

- 98** studio white +\$0

Bar-Pull Add-On Overfile *continued*

Tu® Metal Storage

Bright Sand Texture Paint		
<i>For textured paint on smooth steel (XS)</i>		
91	white	+\$0
CL	cool grey neutral	+\$0
G1	graphite	+\$0
WN	warm grey neutral	+\$0

Step 6. Front Finish		
<i>For laminate front (L.)</i>		
76	light brown walnut	+\$0
8Q	folkstone grey	+\$0
91	white	+\$0
98	studio white	+\$0
CL	cool grey neutral	+\$0
HM	natural maple	+\$0
HP	light anigre	+\$0
HX	aged cherry	+\$0
HY	walnut on cherry	+\$0
LA	light ash	+\$0
LBA	clear on ash	+\$0
LBB	oak on ash	+\$0
LBC	walnut on ash	+\$0
LBD	dark brown walnut	+\$0
LBE	medium red walnut	+\$0
LBF	neutral twill	+\$0
LBG	sarum twill	+\$0
LBH	earthen twill	+\$0
LBJ	graphite twill	+\$0
LBK	pewter mesh	+\$0
LBL	steel mesh	+\$0
LBM	crisp linen	+\$0
LBN	classic linen	+\$0
LBP	casual linen	+\$0
LBQ	white twill	+\$0
LBR	phantom ecru	+\$0
LBS	phantom cocoa	+\$0
LBU	medium matte walnut	+\$0
LBV	warm grey teak	+\$0
LU	soft white	+\$0
WL	sandstone	+\$0
WN	warm grey neutral	+\$0

Step 7. Lock		
KA	keyed alike	+\$0
KC	keyed differently, chrome	+\$0
KD	keyed differently, black	+\$0

Step 8. Pull Finish		
79	green apple <input type="checkbox"/> A	+\$15
8Q	folkstone grey	+\$0
91	white	+\$0
98	studio white	+\$0
CN	metallic champagne <input type="checkbox"/> A	+\$0
G1	graphite <input type="checkbox"/> A	+\$0
MS	metallic silver	+\$0
MY3	yellow oxide <input type="checkbox"/> A	+\$15
RO	red <input type="checkbox"/> A	+\$15
TRQ	turquoise <input type="checkbox"/> A	+\$15
WL	sandstone <input type="checkbox"/> A	+\$0

Arc Pull Add-On Overfile

LQ410D
LQ410L

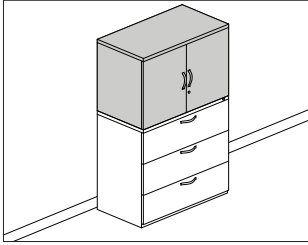

Product Information

Description

This overfile is field installed to the top of a Tu® lateral file. It has hinged doors that open to 110°, a painted front, smooth-steel case and applied metal arc pull. File includes 1 shelf that is binder adjustable. Mounting hardware included.

Actual height is 26¹/₈". Actual depth is 19³/₈". Actual width is 29¹/₂", 35¹/₂", or 41¹/₂" to mount to same-width lateral file.

Notes

Pull design conforms to guidelines of Americans with Disabilities Act (ADA).

Overfile can only be mounted to top of 2-, 3-, or 4-drawer Tu lateral file.

Attachment of overfile requires drilling through top of lateral file.

Not available with veneer front.

For best aesthetics, mount overfile to arc pull lateral file.

Dimensions

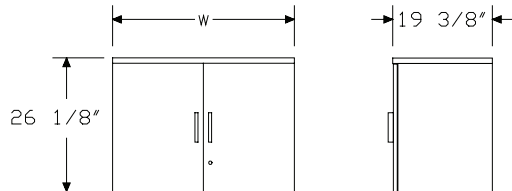

Specification Information

Step 1.

LQ410

Step 2. Front Material

- D. painted metal front
- L. laminate front

Step 3. Width

- 30 30" wide
- 36 36" wide
- 42 42" wide

Prices for Steps 1-3.

LQ410D. 30	\$945
36	\$1067
42	\$1209
LQ410L. 30	\$1087
36	\$1227
42	\$1390

Step 4. Paint/Steel Type

- SS** smooth paint on smooth steel +\$0
- XS** textured paint on smooth steel +\$0

Step 5. Surface Finish

For smooth paint on smooth steel (SS)

- 8Q** folkstone grey +\$0
- 98** studio white +\$0
- BU** black umber +\$0
- CN** metallic champagne +\$65
- EH** metallic bronze +\$65
- HF** inner tone light +\$0
- LT** light tone +\$0
- LU** soft white +\$0
- MS** metallic silver +\$65
- MT** medium tone +\$0
- SG** slate grey +\$0
- WL** sandstone +\$0

Sand Texture Paint

For textured paint on smooth steel (XS)

- 98** studio white +\$0

Bright Sand Texture Paint		
<i>For textured paint on smooth steel (XS)</i>		
91	white	+\$0
CL	cool grey neutral	+\$0
G1	graphite	+\$0
WN	warm grey neutral	+\$0
Step 6. Lock		
KA	keyed alike	+\$0
KC	keyed differently, chrome	+\$0
KD	keyed differently, black	+\$0
Step 7. Pull Finish		
NH	brushed nickel	+\$0
NK	black nickel	+\$0

W-Pull Add-On Overfile

LW410.

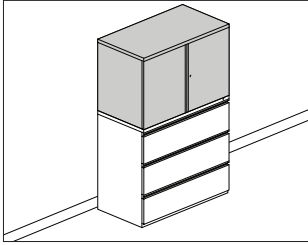

Product Information

Description

This overfile is field installed to the top of a Tu® lateral file. It has hinged doors that open to 110°, a smooth-steel case and full-width integrated pull. File includes 1 shelf that is binder adjustable. Mounting hardware included.

Actual height is 26¹/₈". Actual depth is 19³/₈". Actual width is 29⁷/₈", 35⁵/₈", or 41⁵/₈" to mount to same-width lateral file.

Notes

Overfile can only be mounted to top of 2-, 3-, or 4-drawer Tu lateral file.

Attachment of overfile requires drilling through top of lateral file.

For best aesthetics, mount overfile to W-pull lateral file.

Dimensions

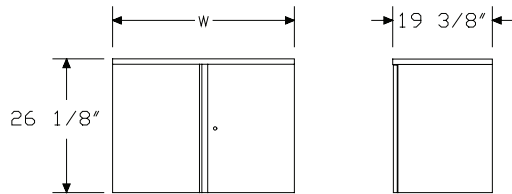

Specification Information

Step 1.

LW410.

Step 2. Width

30	30" wide
36	36" wide
42	42" wide

Prices for Steps 1-2.

LW410. 30	\$942
36	\$1060
42	\$1201

Step 3. Paint/Steel Type

SS	smooth paint on smooth steel	+\$0
XS	textured paint on smooth steel	+\$0

Step 4. Surface Finish

For smooth paint on smooth steel (SS)

8Q	folkstone grey	+\$0
98	studio white	+\$0
BU	black umber	+\$0
CN	metallic champagne	+\$65
EH	metallic bronze	+\$65
HF	inner tone light	+\$0
LT	light tone	+\$0
LU	soft white	+\$0
MS	metallic silver	+\$65
MT	medium tone	+\$0
SG	slate grey	+\$0
WL	sandstone	+\$0

Sand Texture Paint

For textured paint on smooth steel (XS)

98	studio white	+\$0
-----------	--------------	------

Bright Sand Texture Paint

For textured paint on smooth steel (XS)

91	white	+\$0
CL	cool grey neutral	+\$0
G1	graphite	+\$0
WN	warm grey neutral	+\$0

W-Pull Add-On Overfile *continued*

Tu[®] Metal Storage

Step 5. Lock

KA	keyed alike	+\$0
KC	keyed differently, chrome	+\$0
KD	keyed differently, black	+\$0

V-Pull Add-On Overfile

LV410.

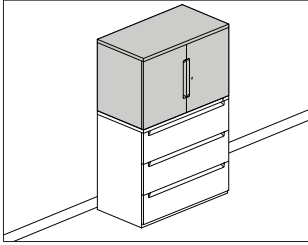

Product Information

Description

This overfile is field installed to the top of a Tu® lateral file. It has hinged doors that open to 110°, a smooth-steel case and full-width recessed pull. File includes 1 shelf that is binder adjustable. Mounting hardware included.

Actual height is 26¹/₈". Actual depth is 19³/₈". Actual width is 29⁷/₈", 35⁵/₈", or 41⁵/₈" to mount to same-width lateral file.

Notes

Overfile can only be mounted to top of 2-, 3-, or 4-drawer Tu lateral file.

Attachment of overfile requires drilling through top of lateral file.

For best aesthetics, mount overfile to V-pull lateral file.

Dimensions

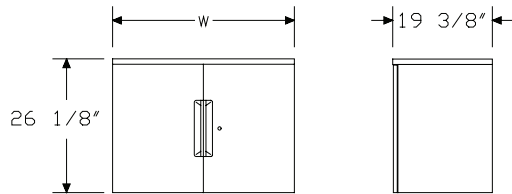

Specification Information

Step 1.

LV410.

Step 2. Width

30	30" wide
36	36" wide
42	42" wide

Prices for Steps 1-2.

LV410. 30	\$940
36	\$1057
42	\$1198

Step 3. Paint/Steel Type

SS	smooth paint on smooth steel	+\$0
XS	textured paint on smooth steel	+\$0

Step 4. Surface Finish

For smooth paint on smooth steel (SS)

8Q	folkstone grey	+\$0
98	studio white	+\$0
BU	black umber	+\$0
CN	metallic champagne	+\$65
EH	metallic bronze	+\$65
HF	inner tone light	+\$0
LT	light tone	+\$0
LU	soft white	+\$0
MS	metallic silver	+\$65
MT	medium tone	+\$0
SG	slate grey	+\$0
WL	sandstone	+\$0

Sand Texture Paint

For textured paint on smooth steel (XS)

98	studio white	+\$0
-----------	--------------	------

Bright Sand Texture Paint

For textured paint on smooth steel (XS)

91	white	+\$0
CL	cool grey neutral	+\$0
G1	graphite	+\$0
WN	warm grey neutral	+\$0

V-Pull Add-On Overfile *continued*

Tu® Metal Storage

Step 5. Lock		
KA	keyed alike	+\$0
KC	keyed differently, chrome	+\$0
KD	keyed differently, black	+\$0

Tu® File Top

LTPL-
LTPV-

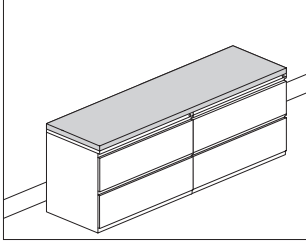

Product Information

Description

This file top attaches to a combination of freestanding Tu® lateral files or storage cases with 20" depths. It has a laminate top with thermoplastic edge or a veneer top and edge.

Notes

Dimensions listed are nominal. Actual dimensions are calculated to work with Tu files and cases. Refer to planning documents on Kiosk/One Stop for exact dimensions and additional details.

Additional sizes and open-line laminates available through Vary Easy® Exact Size Top Price Book (specT edition only).

Dimensions

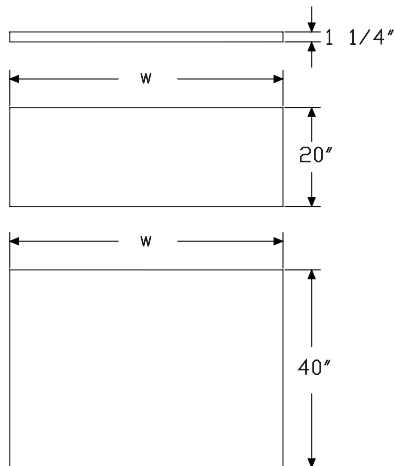

Specification Information

Step 1.

LTP A

Step 2. Top/Edge Material

L- laminate top with thermoplastic edge A

V- veneer top with veneer edge A

Step 3. Width

For laminate top with thermoplastic edge (L-)

- 030** 30" wide A
- 036** 36" wide A
- 042** 42" wide A
- 060** 60" wide A
- 072** 72" wide A
- 084** 84" wide A
- 090** 90" wide A
- 108** 108" wide A

For veneer top with veneer edge (V-)

- 030** 30" wide A
- 036** 36" wide A
- 042** 42" wide A
- 060** 60" wide A
- 072** 72" wide A
- 084** 84" wide A
- 090** 90" wide A

Step 4. Depth

- 20** 20" deep A
- 40** 40" deep A

Prices for Steps 1-4.

		20	40
LTPL-	030	\$212	434
	036	\$232	521
	042	\$271	605
	060	\$396	886
	072	\$475	1063
	084	\$553	1233
	090	\$594	1329
	108	\$711	1594

LTPV-	030	\$482	838
	036	\$540	885
	042	\$598	1001
	060	\$785	1371
	072	\$906	1609
	084	\$1023	1845
	090	\$1080	1959

Step 5. Top/Edge Finish

Solid-Color Laminate Top/Thermoplastic Edge

For laminate top with thermoplastic edge (L-)

8Q	folkstone grey A		+\$0
91	white A		+\$0
98	studio white		+\$0
CL	cool grey neutral A		+\$0
HF	inner tone light A		+\$0
HT	inner tone A		+\$0
LT	light tone A		+\$0
LU	soft white A		+\$0
WL	sandstone A		+\$0
WN	warm grey neutral A		+\$0

Linen Laminate

For laminate top with thermoplastic edge (L-)

LBM	crisp linen		+\$0
LBN	classic linen		+\$0
LBP	casual linen		+\$0

Mesh Laminate

For laminate top with thermoplastic edge (L-)

LBK	pewter mesh		+\$0
LBL	steel mesh		+\$0

Twill Laminate

For laminate top with thermoplastic edge (L-)

LBF	neutral twill		+\$0
LBG	sarum twill		+\$0
LBH	earthen twill		+\$0
LBJ	graphite twill		+\$0
LBQ	white twill		+\$0

Wood-Grain Laminate Top/Thermoplastic Edge

For laminate top with thermoplastic edge (L-)

HM	natural maple A		+\$0
HP	light anigre A		+\$0
LA	light ash A		+\$0
LBA	clear on ash		+\$0
LBB	oak on ash		+\$0
LBC	walnut on ash		+\$0
LBD	dark brown walnut		+\$0
LBR	phantom ecru		+\$0
LBS	phantom cocoa		+\$0
LBU	medium matte walnut		+\$0
LBV	warm grey teak		+\$0
LBE	medium red walnut		+\$0
LM	mahogany A		+\$0
76	light brown walnut A		+\$0
HX	aged cherry A		+\$0
HY	walnut on cherry A		+\$0

Zephyr Laminate Top/Thermoplastic Edge

For laminate top with thermoplastic edge (L-)

28	canyon A		+\$0
29	misted A		+\$0

Recut Veneer

For veneer top with veneer edge (V-)

RA	light ash A		+\$0
RK	mahogany dark A		+\$0
RM	mahogany A		+\$0

Wood Veneer

For veneer top with veneer edge (V-)

2U	light brown walnut A		+\$140
40	dark brown walnut A		+\$140
ED	aged cherry A		+\$140
EK	medium red walnut A		+\$140
EW	medium matte walnut A		+\$140
ET	clear on ash A		+\$140
EU	oak on ash A		+\$140
EV	walnut on ash A		+\$140
UL	natural maple A		+\$140
UX	walnut on cherry A		+\$140

Lateral File Add-On Cushion Top LG891.

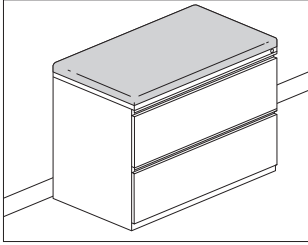

Product Information

Description

This 1"- or 2"-high cushion top is retrofit to a lateral file with a flat metal top and provides temporary guest seating. Hook-and-loop fastener strips are included to attach cushion top to flat metal top.

Notes

Cushion top accepts Customer's Own Material (COM). Yardage is estimated for nondirectional, 54"-wide fabrics. When ordering more than 1 cushion, round up total yardage requirement to next whole yard of fabric.

Width—Yardage

30" —1.05

36" —1.22

42" —1.40

For information on multiple quantities or directional fabrics, contact COM Department. See Order Information in Appendices.

Dimensions

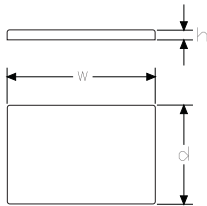

Specification Information

Step 1.

LG891.

Step 2. Height

1 1" high

2 2" high

Step 3. Width

30 30" wide

36 36" wide

42 42" wide

Prices for Steps 1-3.

	30	36	42
LG891. 1	\$227	290	305
2	\$285	324	356

Step 4. Cushion Top Fabric

See application chart and textiles list for fabric usage and numbers.

First 2 digits of number indicate fabric line; remaining digit(s) indicate fabric color.

Price Category 1	+\$0
Price Category 2	+\$102
Price Category 3	+\$123
Price Category 4	+\$151
Price Category 7 A	+\$206
Price Category 9	+\$1425
Price Category B	+\$71
Price Category E	+\$150
Price Category G	+\$251
Price Category H	+\$305

Front-to-Back Filing Rail, Tu®
Lateral File

LG904.

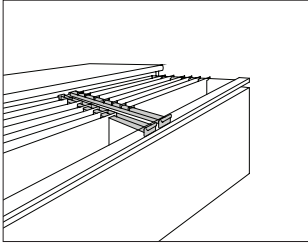

Tu® Metal Storage

Product Information

Description

These black umber filing rails hold letter-, legal-, and A4-size hanging folders for front-to-back filing in a Tu® or Quadrant® lateral file drawer. Package contains 2 rails.

Notes

2 rails accommodate 1 file drawer.

Dimensions

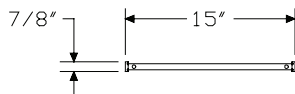

Specification Information

Step 1.

LG904.

Step 2. Width

- 30** for 30"-wide drawers
- 36** for 36"-wide drawers
- 42** for 42"-wide drawers

Prices for Steps 1-2.

LG904. 30	\$37
36	\$37
42	\$37

File Drawer Organizer

LG901

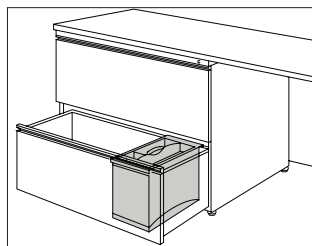

Product Information

Description

This 2-sectioned organizer fits into any file drawer arranged for letter-size filing. The removable top section stores computer disks and other small items. The bottom section stores larger items or can be divided into 3 compartments; it includes 2 vertical dividers. Finish is black umber.

Dimensions

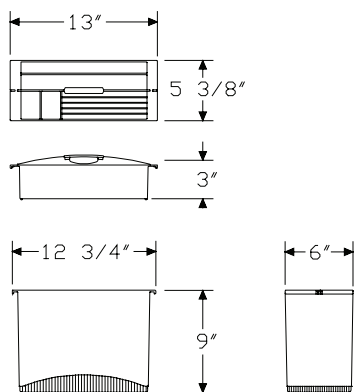

Specification Information

Step 1.

LG901

\$77

Side-to-Side Filing Rail, Tu®
Lateral File

LG902.

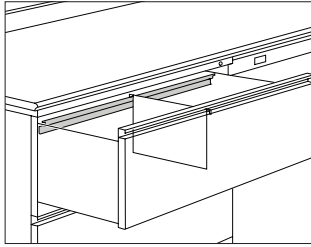

Tu® Metal Storage

Product Information

Description

This filing rail holds letter- or legal-size hanging folders for side-to-side filing in a Tu® or Quadrant® lateral file drawer. Available in 3 sizes: 26½"-wide rail for 30"-wide drawer, 32½"-wide rail for 36"-wide drawer, and 38½"-wide rail for 42"-wide drawer. Package contains 1 rail.

Notes

2 rails are needed per drawer.

Side-to-side filing rail cannot be used in Meridian Stackable™ lateral file drawers, Meridian Stackable Storage™ cabinet bottom module, or Meridian lateral storage tower.

Dimensions

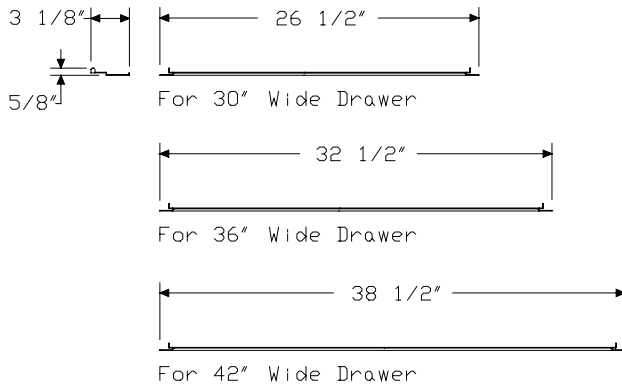

Specification Information

Step 1.

LG902.

Step 2. Width

- 30** for 30"-wide drawers
- 36** for 36"-wide drawers
- 42** for 42"-wide drawers

Prices for Steps 1-2.

LG902. 30	\$24
36	\$24
42	\$24

Movable Divider, Meridian®, 9M100
 Quadrant® or Tu® 9M300

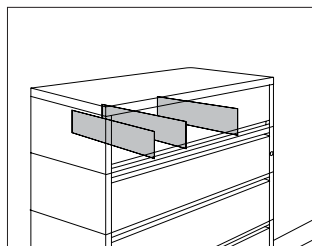

Product Information

Description

This adjustable metal divider fits into slots of an 18"- or 20"-deep Meridian® Stackable™ lateral file drawer. The 18"-deep divider also fits into a pullout shelf's slots on a Tu® or Quadrant® 5-high lateral file. Finish is black umber.

Dimensions

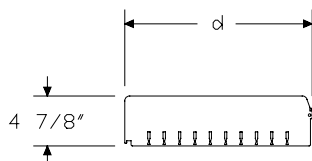

Specification Information

Step 1.

9M

Step 2. Quantity

100 1 divider
300 3 dividers

Step 3. Depth

18 for Meridian® 18"-deep Stackable™ lateral file modules or
 Quadrant® 20" deep flipper door with pullout shelf
20 for Meridian® 20" deep Stackable™ lateral file modules

Prices for Steps 1-3.

9M100	18	\$14
	20	\$14
9M300	18	\$34
	20	\$34

Counterweight, Tu® Lateral File LG909.

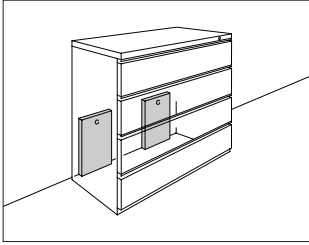

Tu® Metal Storage

Product Information

Description

This counterweight is field installed to the inside back of a Tu® or Quadrant® freestanding lateral file. It provides stability when file is not anchored or ganged to another file. Counterweight for 30" wide file includes 2 plates, counterweight for 36"- or 42"-wide file includes 4 plates. Mounting hardware included.

Dimensions

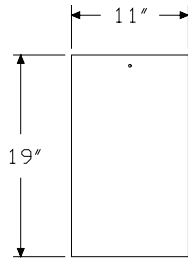

Specification Information

Step 1.

LG909.

Step 2. Width

- 1** for 30"-wide file
- 2** for 36"- or 42"- wide file

Prices for Steps 1-2.

LG909. 1	\$103
2	\$191

Label Holders-Snap In and Adhesive

9LH5H
9LH7H

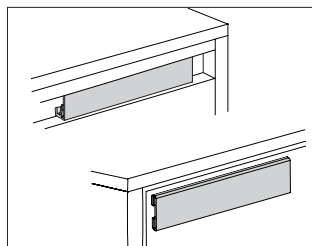

Product Information

Description

These label holders snap in place for standard pull file drawers or attach with adhesive onto drawers with other pull styles. Package contains 25 of the specified style. Labels included.

Dimensions

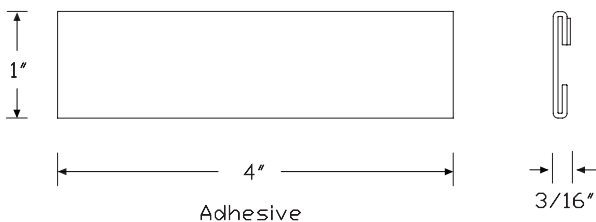
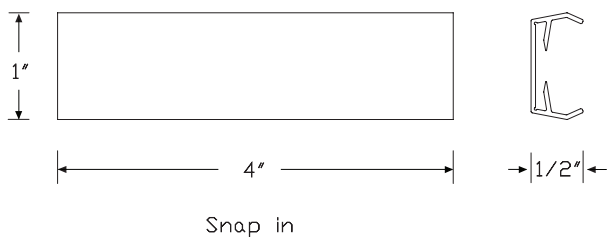

Specification Information

Step 1.

9LH A

Step 2. Style

5HV snap in A

7HT adhesive A

Prices for Steps 1-2.

9LH5HV	\$19
9LH7HT	\$17

Bar-Pull Storage Tower

LK300D
LK300L
LK310D
LK310L

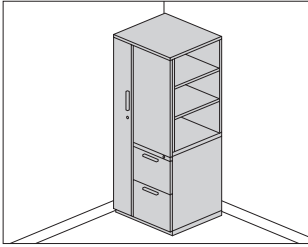

Tu® Metal Storage

Product Information

Description

This freestanding storage tower has a wardrobe on 1 side and the option of a storage case or side-facing bookcase on the other side. Pedestal is located opposite of wardrobe. The tower has a smooth-steel case, painted metal or laminate fronts, applied metal bar pulls, and recessed base with 1" leveling glides. Units with laminate fronts will include a metal top and a metal fascia piece (where lock is located). Available in 9 heights.

Actual tower depth is 23 1/4". Actual tower width is 23 7/8".

9"-wide wardrobe is available with a coat hook or coat rod.

15"-wide storage case is locking and has 1 or 2 adjustable shelves.

Shelves adjust in 1 1/4" increments, starting 7" from the bottom of the storage case.

Side-facing bookcase is 14 1/2" deep and 23 1/4" wide. It includes 1 or 2 adjustable shelves that adjust in 1 1/4" increments.

Pedestal is locking, with one lock securing all drawers. It includes a positive interlock system that permits only 1 drawer to open at a time. Drawers are available in a variety of box and file drawer configurations. Box drawers are available with full-extension or 3/4-extension slides and include a drawer divider, utility tray or storage organizer. File drawers have full-extension slides and hold letter-size front-to-back hanging files. Each file drawer includes file converters for letter-, legal- and A4-size side-to-side hanging files.

Notes

The following chart shows the number of adjustable shelves in each storage case/side-facing bookcase based on tower height:

Height—Shelves

- 46" h (45" actual)—1 shelf
- 53" h (52 1/2" actual)—1 shelf
- 54" h (53 1/2" actual)—1 shelf
- 57" h (56" actual)—1 shelf
- 62" h (61 1/2" actual)—1 shelf
- 65" h (64 1/2" actual)—2 shelves
- 67" h (66 1/2" actual)—2 shelves
- 68" h (67" actual)—2 shelves
- 70" h (69 1/2" actual)—2 shelves

Dimensional illustrations do not include all possible configurations.

Order optional accessories separately:

- File compressor (LG908)
- File drawer organizer (LG901)
- Pedestal stationery divider (LG905)
- Storage organizer (LG910)

Storage organizer includes a hanging file holder, utility tray (pencil tray) and 2 containers. The storage organizer frame color matches the drawer interior; file holder and containers are 91 white; utility tray is black.

All locks in tower are factory installed and are keyed alike within the tower. For specific numbering choices, specify KA and order lock plugs separately. See Keyed-Alike Information in appendices.

Dimensions

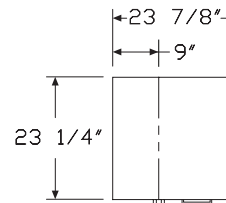

Bar-Pull Storage Tower *continued*

Specification Information

Step 1.
LK3

Step 2. Storage Configuration
00 storage case
10 side-facing bookcase

Step 3. Front Material
D. painted metal
L. laminate front

Step 4. Height
46 46" high
53 53" high
54 54" high
57 57" high
62 62" high
65 65" high
67 67" high
68 68" high
70 70" high

Step 5. Wardrobe Location
L wardrobe left
R wardrobe right

Step 6. Drawer Configuration

For 46" high (46), 53" high (53), 54" high (54), or 57" high (57)
R file/file
S box/box/file

For 62" high (62), 65" high (65), 67" high (67), 68" high (68), or 70" high (70)
R file/file
S box/box/file
T file/file/file
V box/box/file/file

Prices for Steps 1-6.

	R	S	T	V
LK300D. 46 L	\$2297	2299	—	—
R	\$2297	2299	—	—
53 L	\$2333	2337	—	—
R	\$2333	2337	—	—

54 L	\$2357	2359	—	—
R	\$2357	2359	—	—
57 L	\$2380	2384	—	—
R	\$2380	2384	—	—
62 L	\$2517	2519	2754	2761
R	\$2517	2519	2754	2761
65 L	\$2546	2549	2786	2794
R	\$2546	2549	2786	2794
67 L	\$2575	2580	2818	2827
R	\$2575	2580	2818	2827
68 L	\$2460	2463	2692	2700
R	\$2460	2463	2692	2700
70 L	\$2606	2609	2853	2861
R	\$2606	2609	2853	2861

	R	S	T	V
LK300L. 46 L	\$2642	2644	—	—
R	\$2642	2644	—	—
53 L	\$2683	2688	—	—
R	\$2683	2688	—	—
54 L	\$2711	2713	—	—
R	\$2711	2713	—	—
57 L	\$2737	2742	—	—
R	\$2737	2742	—	—
62 L	\$2895	2897	3167	3175
R	\$2895	2897	3167	3175
65 L	\$2928	2931	3204	3213
R	\$2928	2931	3204	3213
67 L	\$2961	2967	3241	3251
R	\$2961	2967	3241	3251
68 L	\$2829	2832	3096	3105
R	\$2829	2832	3096	3105
70 L	\$2997	3000	3281	3290
R	\$2997	3000	3281	3290

	R	S	T	V
LK310D. 46 L	\$2403	2406	—	—
R	\$2403	2406	—	—
53 L	\$2318	2444	—	—
R	\$2318	2444	—	—
54 L	\$2337	2465	—	—
R	\$2337	2465	—	—
57 L	\$2486	2490	—	—
R	\$2486	2490	—	—
62 L	\$2629	2631	2876	2882
R	\$2629	2631	2876	2882

Bar-Pull Storage Tower *continued*

Tu® Metal Storage

	65 L	\$2658	2661	2908	2916	
	R	\$2658	2661	2908	2916	
	67 L	\$2688	2692	2941	2950	
	R	\$2688	2692	2941	2950	
	68 L	\$2567	2570	2809	2817	
	R	\$2567	2570	2809	2817	
	70 L	\$2719	2723	2974	2982	
	R	\$2719	2723	2974	2982	
			R	S	T	V
LK310L	46 L	\$2763	2767	—	—	
	R	\$2763	2767	—	—	
	53 L	\$2666	2811	—	—	
	R	\$2666	2811	—	—	
	54 L	\$2688	2835	—	—	
	R	\$2688	2835	—	—	
	57 L	\$2859	2864	—	—	
	R	\$2859	2864	—	—	
	62 L	\$3023	3026	3307	3314	
	R	\$3023	3026	3307	3314	
	65 L	\$3057	3060	3344	3353	
	R	\$3057	3060	3344	3353	
	67 L	\$3091	3096	3382	3393	
	R	\$3091	3096	3382	3393	
	68 L	\$2952	2956	3230	3240	
	R	\$2952	2956	3230	3240	
	70 L	\$3127	3131	3420	3429	
	R	\$3127	3131	3420	3429	

Step 7. Slides

For file/file (R) or file/file/file (T)

SB	full-extension ball-bearing	+\$0
-----------	-----------------------------	------

For box/box/file (S) or box/box/file/file (V)

SR	3/4-extension roller slides on box drawer, full-extension ball bearing on file drawer	+\$0
SB	full-extension ball-bearing	+\$0
SB	full-extension ball-bearing	+\$50

Step 8. Paint/Steel Type

SS	smooth paint on smooth steel	+\$0
XS	textured paint on smooth steel	+\$0

Step 9. Surface Finish

For smooth paint on smooth steel (SS)

8Q	folkstone grey	+\$0
98	studio white	+\$0
BU	black umber	+\$0
CN	metallic champagne	+\$100
EH	metallic bronze	+\$100
HF	inner tone light	+\$0
LT	light tone	+\$0
LU	soft white	+\$0
MS	metallic silver	+\$100
MT	medium tone	+\$0
SG	slate grey	+\$0
WL	sandstone	+\$0

Sand Texture Paint

For textured paint on smooth steel (XS)

98	studio white	+\$0
-----------	--------------	------

Bright Sand Texture Paint

For textured paint on smooth steel (XS)

91	white	+\$0
CL	cool grey neutral	+\$0
G1	graphite	+\$0
WN	warm grey neutral	+\$0

Step 10. Lock

KA	keyed alike	+\$0
KC	keyed differently, chrome	+\$0
KD	keyed differently, black	+\$0

Step 11. Pull Finish

79	green apple A	+\$15
8Q	folkstone grey	+\$0
91	white	+\$0
98	studio white	+\$0
CN	metallic champagne A	+\$0
G1	graphite A	+\$0
MS	metallic silver	+\$0
MY3	yellow oxide A	+\$15
RO	red A	+\$15
TRQ	turquoise A	+\$15
WL	sandstone A	+\$0

Bar-Pull Storage Tower *continued*

Step 12. Wardrobe Interior

CH	coat hook	+\$0
CR	coat rod	+\$15

Step 13. Drawer Interior

For file/file (R) or file/file/file (T)

NN	none	+\$0
1M	2 file converters in each file drawer	+\$25
C51	storage organizer including hanging file holder bin, utility tray and two containers <input type="checkbox"/> A	+\$120

For box/box/file (S) or box/box/file/file (V)

NN	none	+\$0
2M	drawer divider in box drawers, 2 file converters in file drawer	+\$25
3M	drawer divider in one box drawer, pencil tray in one box drawer, 2 file converters in file drawer	+\$25
C51	storage organizer including hanging file holder bin, utility tray and two containers <input type="checkbox"/> A	+\$120

Arc Pull Storage Tower

LQ300D
LQ300L
LQ310D
LQ310L

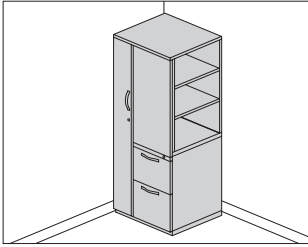

Tu® Metal Storage

Product Information

Description

This freestanding storage tower has a wardrobe on 1 side and the option of a storage case or side-facing bookcase on the other side. Pedestal is located opposite of wardrobe. The tower has a smooth-steel case, painted metal or laminate fronts, applied metal arc pulls, and recessed base with 1" leveling glides. Units with laminate fronts will include a metal top and a metal fascia piece (where lock is located). Available in 9 heights.

Actual tower depth is 23 1/4". Actual tower width is 23 7/8".

9"-wide wardrobe is available with a coat hook or coat rod.

15"-wide storage case is locking and has 1 or 2 adjustable shelves.

Shelves adjust in 1 1/4" increments, starting 7" from the bottom of the storage case.

Side-facing bookcase is 14 1/2" deep and 23 1/4" wide. It includes 1 or 2 adjustable shelves that adjust in 1 1/4" increments.

Pedestal is locking, with one lock securing all drawers. It includes a positive interlock system that permits only 1 drawer to open at a time. Drawers are available in a variety of box and file drawer configurations. Box drawers are available with full-extension or 3/4-extension slides and include a drawer divider, utility tray or storage organizer. File drawers have full-extension slides and hold letter-size front-to-back hanging files. Each file drawer includes file converters for letter-, legal- and A4-size side-to-side hanging files.

Notes

Pull design conforms to guidelines of Americans with Disabilities Act (ADA).

The following chart shows the number of adjustable shelves in each storage case/side-facing bookcase based on tower height:

Height—Shelves

- 46" h (45" actual)—1 shelf
- 53" h (52 1/2" actual)—1 shelf
- 54" h (53 1/2" actual)—1 shelf
- 57" h (56" actual)—1 shelf
- 62" h (61 1/2" actual)—1 shelf
- 65" h (64 1/2" actual)—2 shelves
- 67" h (66 1/2" actual)—2 shelves
- 68" h (67" actual)—2 shelves
- 70" h (69 1/2" actual)—2 shelves

Dimensional illustrations do not include all possible configurations.

Order optional accessories separately:

- File compressor (LG908)
- File drawer organizer (LG901)
- Pedestal stationery divider (LG905)
- Storage organizer (LG910)

Storage organizer includes a hanging file holder, utility tray (pencil tray) and 2 containers. The storage organizer frame color matches the drawer interior; file holder and containers are 91 white; utility tray is black.

All locks in tower are factory installed and are keyed alike within the tower. For specific numbering choices, specify KA and order lock plugs separately. See Keyed-Alike Information in appendices.

Dimensions

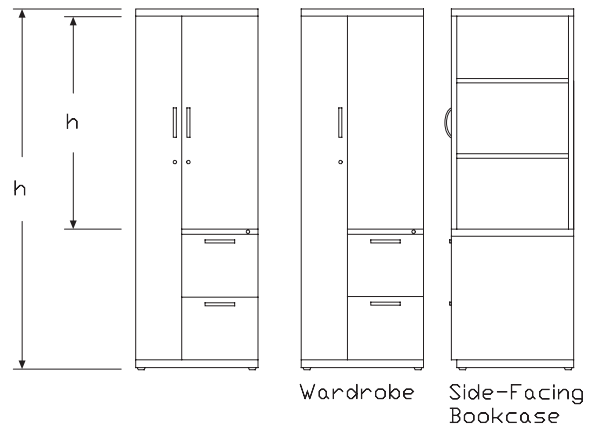
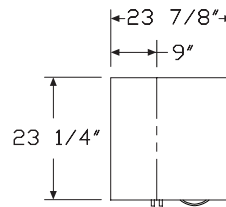

Specification Information

Step 1.

LQ3

Step 2. Storage Configuration

00 storage case

10 side-facing bookcase

Step 3. Front Material

D. painted metal

L. laminate front

Step 4. Height

46 46" high

53 53" high

54 54" high

57 57" high

62 62" high

65 65" high

67 67" high

68 68" high

70 70" high

Step 5. Wardrobe Location

L wardrobe left

R wardrobe right

Step 6. Drawer Configuration

For 46" high (46), 53" high (53), 54" high (54), or 57" high (57)

R file/file

S box/box/file

For 62" high (62), 65" high (65), 67" high (67), 68" high (68), or 70" high (70)

R file/file

S box/box/file

T file/file/file

V box/box/file/file

Prices for Steps 1-6.

	R	S	T	V
LQ300D. 46 L	\$2297	2299	—	—
R	\$2297	2299	—	—
53 L	\$2333	2337	—	—
R	\$2333	2337	—	—

54 L	\$2357	2359	—	—
R	\$2357	2359	—	—
57 L	\$2380	2384	—	—
R	\$2380	2384	—	—
62 L	\$2517	2519	2754	2761
R	\$2517	2519	2754	2761
65 L	\$2546	2549	2786	2794
R	\$2546	2549	2786	2794
67 L	\$2575	2580	2818	2827
R	\$2575	2580	2818	2827
68 L	\$2460	2463	2692	2700
R	\$2460	2463	2692	2700
70 L	\$2606	2609	2853	2861
R	\$2606	2609	2853	2861

	R	S	T	V
LQ300L. 46 L	\$2642	2644	—	—
R	\$2642	2644	—	—
53 L	\$2683	2688	—	—
R	\$2683	2688	—	—
54 L	\$2711	2713	—	—
R	\$2711	2713	—	—
57 L	\$2737	2742	—	—
R	\$2737	2742	—	—
62 L	\$2895	2897	3167	3175
R	\$2895	2897	3167	3175
65 L	\$2928	2931	3204	3213
R	\$2928	2931	3204	3213
67 L	\$2961	2967	3241	3251
R	\$2961	2967	3241	3251
68 L	\$2829	2832	3096	3105
R	\$2829	2832	3096	3105
70 L	\$2997	3000	3281	3290
R	\$2997	3000	3281	3290

	R	S	T	V
LQ310D. 46 L	\$2403	2406	—	—
R	\$2403	2406	—	—
53 L	\$2318	2444	—	—
R	\$2318	2444	—	—
54 L	\$2337	2465	—	—
R	\$2337	2465	—	—
57 L	\$2486	2490	—	—
R	\$2486	2490	—	—
62 L	\$2629	2631	2876	2882
R	\$2629	2631	2876	2882

Arc Pull Storage Tower *continued*

Tu® Metal Storage

	65 L	\$2658	2661	2908	2916	
	R	\$2658	2661	2908	2916	
	67 L	\$2688	2692	2941	2950	
	R	\$2688	2692	2941	2950	
	68 L	\$2567	2570	2809	2817	
	R	\$2567	2570	2809	2817	
	70 L	\$2719	2723	2974	2982	
	R	\$2719	2723	2974	2982	
			R	S	T	V
LQ310L.	46 L	\$2763	2767	—	—	
	R	\$2763	2767	—	—	
	53 L	\$2666	2811	—	—	
	R	\$2666	2811	—	—	
	54 L	\$2688	2835	—	—	
	R	\$2688	2835	—	—	
	57 L	\$2859	2864	—	—	
	R	\$2859	2864	—	—	
	62 L	\$3023	3026	3307	3314	
	R	\$3023	3026	3307	3314	
	65 L	\$3057	3060	3344	3353	
	R	\$3057	3060	3344	3353	
	67 L	\$3091	3096	3382	3393	
	R	\$3091	3096	3382	3393	
	68 L	\$2952	2956	3230	3240	
	R	\$2952	2956	3230	3240	
	70 L	\$3127	3131	3420	3429	
	R	\$3127	3131	3420	3429	

Step 7. Slides

For file/file (R) or file/file/file (T)

SB	full-extension ball-bearing	\$0
-----------	-----------------------------	-----

For box/box/file (S) or box/box/file/file (V)

SR	3/4-extension roller slides on box drawer, full-extension ball bearing on file drawer	\$0
SB	full-extension ball-bearing	\$50

Step 8. Paint/Steel Type

SS	smooth paint on smooth steel	\$0
XS	textured paint on smooth steel	\$0

Step 9. Surface Finish

For smooth paint on smooth steel (SS)

8Q	folkstone grey	\$0
98	studio white	\$0
BU	black umber	\$0
CN	metallic champagne	\$100
EH	metallic bronze	\$100
HF	inner tone light	\$0
LT	light tone	\$0
LU	soft white	\$0
MS	metallic silver	\$100
MT	medium tone	\$0
SG	slate grey	\$0
WL	sandstone	\$0

Sand Texture Paint

For textured paint on smooth steel (XS)

98	studio white	\$0
-----------	--------------	-----

Bright Sand Texture Paint

For textured paint on smooth steel (XS)

91	white	\$0
CL	cool grey neutral	\$0
G1	graphite	\$0
WN	warm grey neutral	\$0

Step 10. Lock

KA	keyed alike	\$0
KC	keyed differently, chrome	\$0
KD	keyed differently, black	\$0

Step 11. Pull Finish

NH	brushed nickel	\$0
NK	black nickel	\$0

Step 12. Wardrobe Interior

CH	coat hook	\$0
CR	coat rod	\$15

Arc Pull Storage Tower *continued*

Step 13. Drawer Interior

For file/file (R) or file/file/file (T)

NN	none	+\$0
1M	2 file converters in each file drawer	+\$25
C51	storage organizer including hanging file holder bin, utility tray and two containers <input type="checkbox"/> A	+\$120

For box/box/file (S) or box/box/file/file (V)

NN	none	+\$0
2M	drawer divider in box drawers, 2 file converters in file drawer	+\$25
3M	drawer divider in one box drawer, pencil tray in one box drawer, 2 file converters in file drawer	+\$25
C51	storage organizer including hanging file holder bin, utility tray and two containers <input type="checkbox"/> A	+\$120

W-Pull Storage Tower

LW300.
LW310.

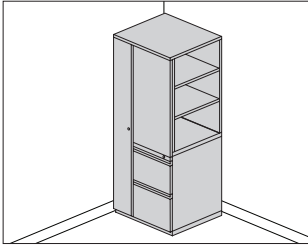

Tu® Metal Storage

Product Information

Description

This freestanding storage tower has a wardrobe on 1 side and the option of a storage case or side-facing bookcase on the other side. Pedestal is located opposite of wardrobe. The tower has a smooth-steel case, full-width pulls, and recessed base with 1" leveling glides. Available in 9 heights.

Actual tower depth is 23 1/4". Actual tower width is 23 7/8".

9"-wide wardrobe is available with a coat hook or coat rod.

15"-wide storage case is locking and has 1 or 2 adjustable shelves.

Shelves adjust in 1 1/4" increments, starting 7" from the bottom of the storage case.

Side-facing bookcase is 14 1/2" deep and 23 1/4" wide. It includes 1 or 2 adjustable shelves that adjust in 1 1/4" increments.

Pedestal is locking, with one lock securing all drawers. It includes a positive interlock system that permits only 1 drawer to open at a time. Drawers are available in a variety of box and file drawer configurations. Box drawers are available with full-extension or 3/4-extension slides and include a drawer divider, utility tray or storage organizer. File drawers have full-extension slides and hold letter-size front-to-back hanging files. File converters are optional for letter-, legal- and A4-size side-to-side hanging files.

Notes

The following chart shows the number of adjustable shelves in each storage case/side-facing bookcase based on tower height:

Height — Shelves

- 46" h (45" actual) — 1 shelf
- 53" h (52 1/2" actual) — 1 shelf
- 54" h (53 1/2" actual) — 1 shelf
- 57" h (56" actual) — 1 shelf
- 62" h (61 1/2" actual) — 1 shelf
- 65" h (64 1/2" actual) — 2 shelves
- 67" h (66 1/2" actual) — 2 shelves
- 68" h (67" actual) — 2 shelves
- 70" h (69 1/2" actual) — 2 shelves

Dimensional illustrations do not include all possible configurations.

Order optional accessories separately:

- File compressor (LG908)
- File drawer organizer (LG901)
- Pedestal stationery divider (LG905)
- Storage organizer (LG910)

Storage organizer includes a hanging file holder, utility tray (pencil tray) and 2 containers. The storage organizer frame color matches the drawer interior; file holder and containers are 91 white; utility tray is black.

All locks in tower are factory installed and are keyed alike within the tower. For specific numbering choices, specify KA and order lock plugs separately. See Keyed-Alike Information in Appendices.

Dimensions

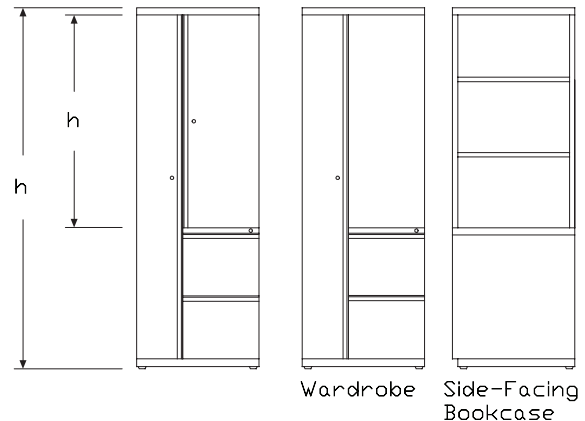
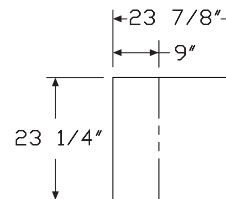

W-Pull Storage Tower *continued*

Specification Information

Step 1.

LW3

Step 2. Storage Configuration

- 00.** storage case
- 10.** side-facing bookcase

Step 3. Height

- 46** 46" high
- 53** 53" high
- 54** 54" high
- 57** 57" high
- 62** 62" high
- 65** 65" high
- 67** 67" high
- 68** 68" high
- 70** 70" high

Step 4. Wardrobe Location

- L** wardrobe left
- R** wardrobe right

Step 5. Drawer Configuration

For 46" high (46), 53" high (53), 54" high (54), or 57" high (57)

- R** file/file
- S** box/box/file

For 62" high (62), 65" high (65), 67" high (67), 68" high (68), or 70" high (70)

- R** file/file
- S** box/box/file
- T** file/file/file
- V** box/box/file/file

Prices for Steps 1-5.

	R	S	T	V
LW300. 46 L	\$2025	2059	—	—
R	\$2025	2059	—	—
53 L	\$2057	2092	—	—
R	\$2057	2092	—	—
54 L	\$2077	2113	—	—
R	\$2077	2113	—	—
57 L	\$2098	2136	—	—
R	\$2098	2136	—	—

62 L	\$2174	2211	2376	2417
R	\$2174	2211	2376	2417
65 L	\$2202	2238	2407	2446
R	\$2202	2238	2407	2446
67 L	\$2226	2263	2434	2474
R	\$2226	2263	2434	2474
68 L	\$2172	2207	2374	2412
R	\$2172	2207	2374	2412
70 L	\$2252	2289	2462	2502
R	\$2252	2289	2462	2502

	R	S	T	V
LW310. 46 L	\$2120	2154	—	—
R	\$2120	2154	—	—
53 L	\$2152	2188	—	—
R	\$2152	2188	—	—
54 L	\$2173	2210	—	—
R	\$2173	2210	—	—
57 L	\$2194	2231	—	—
R	\$2194	2231	—	—
62 L	\$2273	2310	2485	2525
R	\$2273	2310	2485	2525
65 L	\$2300	2337	2515	2554
R	\$2300	2337	2515	2554
67 L	\$2326	2362	2542	2582
R	\$2326	2362	2542	2582
68 L	\$2268	2303	2478	2516
R	\$2268	2303	2478	2516
70 L	\$2351	2389	2570	2612
R	\$2351	2389	2570	2612

Step 6. Slides

For file/file (R) or file/file/file (T)

- SB** full-extension ball-bearing +\$0

For box/box/file (S) or box/box/file/file (V)

- SR** ¾-extension roller slides on box drawer, full-extension ball bearing on file drawer +\$0
- SB** full-extension ball-bearing +\$50

Step 7. Paint/Steel Type

- SS** smooth paint on smooth steel +\$0
- XS** textured paint on smooth steel +\$0

W-Pull Storage Tower *continued*

Tu® Metal Storage

Step 8. Surface Finish

For smooth paint on smooth steel (SS)

8Q	folkstone grey	+\$0
98	studio white	+\$0
BU	black umber	+\$0
CN	metallic champagne	+\$100
EH	metallic bronze	+\$100
HF	inner tone light	+\$0
LT	light tone	+\$0
LU	soft white	+\$0
MS	metallic silver	+\$100
MT	medium tone	+\$0
SG	slate grey	+\$0
WL	sandstone	+\$0

Sand Texture Paint

For textured paint on smooth steel (XS)

98	studio white	+\$0
-----------	--------------	------

Bright Sand Texture Paint

For textured paint on smooth steel (XS)

91	white	+\$0
CL	cool grey neutral	+\$0
G1	graphite	+\$0
WN	warm grey neutral	+\$0

Step 9. Lock

KA	keyed alike	+\$0
KC	keyed differently, chrome	+\$0
KD	keyed differently, black	+\$0

Step 10. Wardrobe Interior

CH	coat hook	+\$0
CR	coat rod	+\$15

Step 11. Drawer Interior

For file/file (R) or file/file/file (T)

NN	none	+\$0
1M	2 file converters in each file drawer	+\$25
C51	storage organizer including hanging file holder bin, utility tray and two containers A	+\$120

For box/box/file (S) or box/box/file/file (V)

NN	none	+\$0
2M	drawer divider in box drawers, 2 file converters in file drawer	+\$25
3M	drawer divider in one box drawer, pencil tray in one box drawer, 2 file converters in file drawer	+\$25
C51	storage organizer including hanging file holder bin, utility tray and two containers A	+\$120

V-Pull Storage Tower

LV300.
LV310.

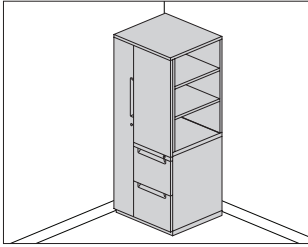

Product Information

Description

This freestanding storage tower has a wardrobe on 1 side and the option of a storage case or side-facing bookcase on the other side. Pedestal is located opposite of wardrobe. The tower has a smooth-steel case, full-width recessed pulls, and recessed base with 1" leveling glides.

Available in 9 heights.

Actual tower depth is 23 1/4". Actual tower width is 23 7/8".

9"-wide wardrobe is available with a coat hook or coat rod.

15"-wide storage case is locking and has 1 or 2 adjustable shelves.

Shelves adjust in 1 1/4" increments, starting 7" from the bottom of the storage case.

Side-facing bookcase is 14 1/2" deep and 23 1/4" wide. It includes 1 or 2 adjustable shelves that adjust in 1 1/4" increments.

Pedestal is locking, with one lock securing all drawers. It includes a positive interlock system that permits only 1 drawer to open at a time. Drawers are available in a variety of box and file drawer configurations. Box drawers are available with full-extension or 3/4-extension slides and include a drawer divider, utility tray, or storage organizer. File drawers have full-extension slides and hold letter-size front-to-back hanging files. File converters are optional for letter-, legal- and A4-size side-to-side hanging files.

Notes

The following chart shows the number of adjustable shelves in each storage case/side-facing bookcase based on tower height:

Height—Shelves

- 46" h (45" actual)—1 shelf
- 53" h (52 1/2" actual)—1 shelf
- 54" h (53 1/2" actual)—1 shelf
- 57" h (56" actual)—1 shelf
- 62" h (61 1/2" actual)—1 shelf
- 65" h (64 1/2" actual)—2 shelves
- 67" h (66 1/2" actual)—2 shelves
- 68" h (67" actual)—2 shelves
- 70" h (69 1/2" actual)—2 shelves

Dimensional illustrations do not include all possible configurations.

Order optional accessories separately:

- File compressor (LG908)
- File drawer organizer (LG901)
- Pedestal stationery divider (LG905)
- Storage organizer (LG910)

Storage organizer includes a hanging file holder, utility tray (pencil tray) and 2 containers. The storage organizer frame color matches the drawer interior; file holder and containers are g1 white; utility tray is black.

All locks in tower are factory installed and are keyed alike within the tower. For specific numbering choices, specify KA and order lock plugs separately. See Keyed-Alike Information in Appendices.

Dimensions

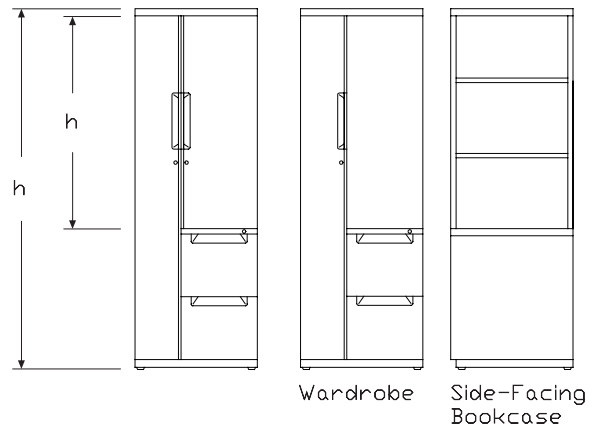
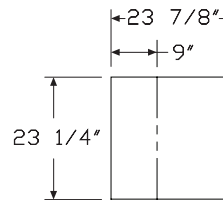

V-Pull Storage Tower *continued*

Tu® Metal Storage

Specification Information

Step 1.

LV3

Step 2. Storage Configuration

- 00.** storage case
- 10.** side-facing bookcase

Step 3. Height

- 46** 46" high
- 53** 53" high
- 54** 54" high
- 57** 57" high
- 62** 62" high
- 65** 65" high
- 67** 67" high
- 68** 68" high
- 70** 70" high

Step 4. Wardrobe Location

- L** wardrobe left
- R** wardrobe right

Step 5. Drawer Configuration

For 46" high (46), 53" high (53), 54" high (54), or 57" high (57)

- R** file/file
- S** box/box/file

For 62" high (62), 65" high (65), 67" high (67), 68" high (68), or 70" high (70)

- R** file/file
- S** box/box/file
- T** file/file/file
- V** box/box/file/file

Prices for Steps 1-5.

	R	S	T	V
LV300. 46 L	\$2295	2333	—	—
R	\$2295	2333	—	—
53 L	\$2330	2372	—	—
R	\$2330	2372	—	—
54 L	\$2353	2395	—	—
R	\$2353	2395	—	—
57 L	\$2378	2421	—	—
R	\$2378	2421	—	—

62 L	\$2463	2504	2693	2739
R	\$2463	2504	2693	2739
65 L	\$2494	2535	2727	2772
R	\$2494	2535	2727	2772
67 L	\$2525	2565	2759	2643
R	\$2525	2565	2759	2643
68 L	\$2460	2500	2688	2734
R	\$2460	2500	2688	2734
70 L	\$2554	2596	2791	2838
R	\$2554	2596	2791	2838

	R	S	T	V
LV310. 46 L	\$2403	2443	—	—
R	\$2403	2443	—	—
53 L	\$2439	2480	—	—
R	\$2439	2480	—	—
54 L	\$2462	2503	—	—
R	\$2462	2503	—	—
57 L	\$2487	2529	—	—
R	\$2487	2529	—	—
62 L	\$2575	2617	2814	2861
R	\$2575	2617	2814	2861
65 L	\$2606	2648	2848	2895
R	\$2606	2648	2848	2895
67 L	\$2636	2677	2882	2927
R	\$2636	2677	2882	2927
68 L	\$2568	2609	2809	2852
R	\$2568	2609	2809	2852
70 L	\$2665	2708	2913	2961
R	\$2665	2708	2913	2961

Step 6. Slides

For file/file (R) or file/file/file (T)

- SB** full-extension ball-bearing +\$0

For box/box/file (S) or box/box/file/file (V)

- SR** 3/4-extension roller slides on box drawer, full-extension ball bearing on file drawer +\$0
- SB** full-extension ball-bearing +\$50

Step 7. Paint/Steel Type

- SS** smooth paint on smooth steel +\$0
- XS** textured paint on smooth steel +\$0

V-Pull Storage Tower *continued*

Step 8. Surface Finish

For smooth paint on smooth steel (SS)

8Q	folkstone grey	+\$0
98	studio white	+\$0
BU	black umber	+\$0
CN	metallic champagne	+\$100
EH	metallic bronze	+\$100
HF	inner tone light	+\$0
LT	light tone	+\$0
LU	soft white	+\$0
MS	metallic silver	+\$100
MT	medium tone	+\$0
SG	slate grey	+\$0
WL	sandstone	+\$0

Sand Texture Paint

For textured paint on smooth steel (XS)

98	studio white	+\$0
-----------	--------------	------

Bright Sand Texture Paint

For textured paint on smooth steel (XS)

91	white	+\$0
CL	cool grey neutral	+\$0
G1	graphite	+\$0
WN	warm grey neutral	+\$0

Step 9. Lock

KA	keyed alike	+\$0
KC	keyed differently, chrome	+\$0
KD	keyed differently, black	+\$0

Step 10. Wardrobe Interior

CH	coat hook	+\$0
CR	coat rod	+\$15

Step 11. Drawer Interior

For file/file (R) or file/file/file (T)

NN	none	+\$0
1M	2 file converters in each file drawer	+\$25
C51	storage organizer including hanging file holder bin, utility tray and two containers <input type="checkbox"/> A	+\$120

For box/box/file (S) or box/box/file/file (V)

NN	none	+\$0
2M	drawer divider in box drawers, 2 file converters in file drawer	+\$25
3M	drawer divider in one box drawer, pencil tray in one box drawer, 2 file converters in file drawer	+\$25
C51	storage organizer including hanging file holder bin, utility tray and two containers <input type="checkbox"/> A	+\$120

W-Pull Storage Tower, No
Wardrobe

LW320.
LW330.

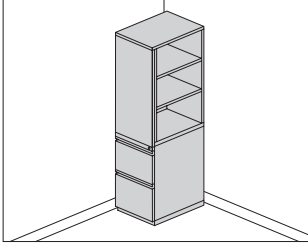

Tu® Metal Storage

Product Information

Description

This freestanding storage tower has a pedestal in the lower section and the option of a storage case or side-facing bookcase above. It has a smooth-steel case, full-width pulls, and recessed base with 1" leveling glides.

Storage case is locking and has 1 or 2 adjustable shelves. Shelves adjust in 1 1/4" increments.

Side-facing bookcase is 14 1/2" deep and 23 1/4" wide. It includes 1 or 2 adjustable shelves (except 42" high) that adjust in 1 1/4" increments.

Pedestal is locking, with one lock securing all drawers. It includes a positive interlock system that permits only 1 drawer to open at a time. Drawers are available in box/box/file or file/file configuration. Box drawers are available with full-extension or 3/4-extension slides and include a drawer divider, utility tray or storage organizer. File drawers have full-extension slides and hold letter-size front-to-back hanging files. File converters are optional for letter-, legal- and A4-size side-to-side hanging files.

Notes

The following chart shows the number of adjustable shelves in each storage case/side-facing bookcase based on tower height:

Height—Shelves

42" h (41" actual)—0 shelves

46" h (45" actual)—1 shelf

57" h (56" actual)—1 shelf

68" h (67" actual)—2 shelves

Order optional accessories separately:

- File compressor (LG908)
- File drawer organizer (LG901)
- Pedestal stationery divider (LG905)
- Storage organizer (LG910)

Storage organizer includes a hanging file holder, utility tray (pencil tray) and 2 containers. The storage organizer frame color matches the drawer interior; file holder and containers are 91 white; utility tray is black.

All locks in tower are factory installed and are keyed alike within the tower. For specific numbering choices, specify KA and order lock plugs separately. See Keyed-Alike Information in Appendices.

Dimensions

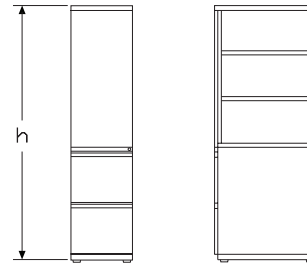
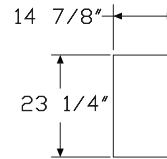

W-Pull Storage Tower, No Wardrobe *continued*

Specification Information

Step 1.

LW3

Step 2. Storage Configuration

20. storage case

30. side-facing bookcase

Step 3. Height

For storage case (20.)

46 46" high

57 57" high

68 68" high

For side-facing bookcase (30.)

42 42" high

46 46" high

57 57" high

68 68" high

Step 4. Door or Bookcase Direction

L left-hinged door or left-facing bookcase

R right-hinged door or right-facing bookcase

Step 5. Drawer Configuration

R file/file

S box/box/file

Prices for Steps 1-5.

	R	S
LW320. 46 L	\$1429	1454
R	\$1429	1454
57 L	\$1482	1506
R	\$1482	1506
68 L	\$1533	1560
R	\$1533	1560
	R	S
LW330. 42 L	\$1420	1442
R	\$1420	1442
46 L	\$1470	1496
R	\$1470	1496
57 L	\$1524	1550
R	\$1524	1550
68 L	\$1577	1605
R	\$1577	1605

Step 6. Slides

For file/file (R)

SB full-extension ball-bearing +\$0

For box/box/file (S)

SR ¾-extension roller slides on box drawer, full-extension ball bearing on file drawer +\$0

SB full-extension ball-bearing +\$50

Step 7. Paint/Steel Type

SS smooth paint on smooth steel +\$0

XS textured paint on smooth steel +\$0

Step 8. Surface Finish

For smooth paint on smooth steel (SS)

8Q folkstone grey +\$0

98 studio white +\$0

BU black umber +\$0

CN metallic champagne +\$75

EH metallic bronze +\$75

HF inner tone light +\$0

LT light tone +\$0

LU soft white +\$0

MS metallic silver +\$75

MT medium tone +\$0

SG slate grey +\$0

WL sandstone +\$0

Sand Texture Paint

For textured paint on smooth steel (XS)

98 studio white +\$0

Bright Sand Texture Paint

For textured paint on smooth steel (XS)

91 white +\$0

CL cool grey neutral +\$0

G1 graphite +\$0

WN warm grey neutral +\$0

Step 9. Lock

KA keyed alike +\$0

KC keyed differently, chrome +\$0

KD keyed differently, black +\$0

W-Pull Storage Tower, No
Wardrobe *continued*

Tu® Metal Storage

Step 10. Drawer Interior

For file/file (R)

NN	none	+\$0
1M	2 file converters in each file drawer	+\$25
C51	storage organizer including hanging file holder bin, utility tray and two containers <input type="checkbox"/> A	+\$120

For box/box/file (S)

NN	none	+\$0
2M	drawer divider in box drawers, 2 file converters in file drawer	+\$25
3M	drawer divider in one box drawer, pencil tray in one box drawer, 2 file converters in file drawer	+\$25
C51	storage organizer including hanging file holder bin, utility tray and two containers <input type="checkbox"/> A	+\$120

V-Pull Storage Tower, No Wardrobe

LV320.
LV330.

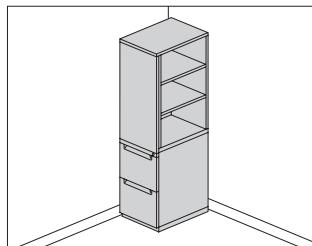

Product Information

Description

This freestanding storage tower has a pedestal in the lower section and the option of a storage case or side-facing bookcase above. It has a smooth-steel case, full-width recessed pulls, and recessed base with 1" leveling glides.

Storage case is locking and has 1 or 2 adjustable shelves. Shelves adjust in 1 1/4" increments.

Side-facing bookcase is 14 1/2" deep and 23 3/4" wide. It includes 1 or 2 adjustable shelves (except 42" high) that adjust in 1 1/4" increments.

Pedestal is locking, with one lock securing all drawers. It includes a positive interlock system that permits only 1 drawer to open at a time. Drawers are available in box/box/file or file/file configuration. Box drawers are available with full-extension or 3/4-extension slides. File drawers have full-extension slides and hold letter-size front-to-back hanging files. File converters are optional for letter-, legal- and A4-size side-to-side hanging files.

Notes

42"-high tower is available with side-facing bookcase only.

The following chart shows the number of adjustable shelves in each storage case/side-facing bookcase based on tower height:

Height—Shelves

42" h (41" actual)—0 shelves

46" h (45" actual)—1 shelf

57" h (56" actual)—1 shelf

68" h (67" actual)—2 shelves

Order optional accessories separately:

- File compressor (LG908)
- File drawer organizer (LG901)
- Pedestal stationery divider (LG905)
- Storage organizer (LG910)

Storage organizer includes a hanging file holder, utility tray (pencil tray) and 2 containers. The storage organizer frame color matches the drawer interior; file holder and containers are 91 white; utility tray is black.

All locks in tower are factory installed and are keyed alike within the tower. For specific numbering choices, specify KA and order lock plugs separately. See Keyed-Alike Information in Appendices.

Dimensions

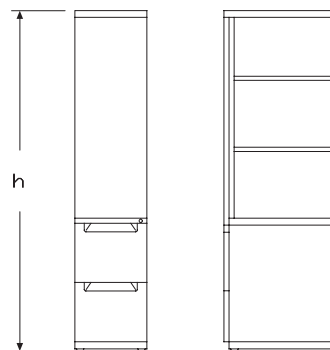
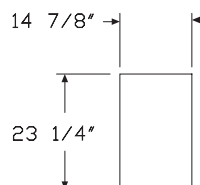

V-Pull Storage Tower, No Wardrobe *continued*

Specification Information

Step 1.

LV3

Step 2. Storage Configuration

- 20.** storage case
- 30.** side-facing bookcase

Step 3. Height

For storage case (20.)

- 46** 46" high
- 57** 57" high
- 68** 68" high

For side-facing bookcase (30.)

- 42** 42" high
- 46** 46" high
- 57** 57" high
- 68** 68" high

Step 4. Door or Bookcase Direction

- L** left-hinged door or left-facing bookcase
- R** right-hinged door or right-facing bookcase

Step 5. Drawer Configuration

- R** file/file
- S** box/box/file

Prices for Steps 1-5.

	R	S
LV320. 46 L	\$1615	1643
R	\$1615	1643
57 L	\$1673	1703
R	\$1673	1703
68 L	\$1732	1763
R	\$1732	1763
	R	S
LV330. 42 L	\$1604	1631
R	\$1604	1631
46 L	\$1662	1691
R	\$1662	1691
57 L	\$1721	1750
R	\$1721	1750
68 L	\$1783	1814
R	\$1783	1814

Step 6. Slides

For file/file (R)

- SB** full-extension ball-bearing +\$0

For box/box/file (S)

- SR** 3/4-extension roller slides on box drawer, full-extension ball bearing on file drawer +\$0
- SB** full-extension ball-bearing +\$50

Step 7. Paint/Steel Type

- SS** smooth paint on smooth steel +\$0
- XS** textured paint on smooth steel +\$0

Step 8. Surface Finish

For smooth paint on smooth steel (SS)

- 8Q** folkstone grey +\$0
- 98** studio white +\$0
- BU** black umber +\$0
- CN** metallic champagne +\$75
- EH** metallic bronze +\$75
- HF** inner tone light +\$0
- LT** light tone +\$0
- LU** soft white +\$0
- MS** metallic silver +\$75
- MT** medium tone +\$0
- SG** slate grey +\$0
- WL** sandstone +\$0

Sand Texture Paint

For textured paint on smooth steel (XS)

- 98** studio white +\$0

Bright Sand Texture Paint

For textured paint on smooth steel (XS)

- 91** white +\$0
- CL** cool grey neutral +\$0
- G1** graphite +\$0
- WN** warm grey neutral +\$0

Step 9. Lock

- KA** keyed alike +\$0
- KC** keyed differently, chrome +\$0
- KD** keyed differently, black +\$0

V-Pull Storage Tower, No
Wardrobe *continued*

Step 10. Drawer Interior

For file/file (R)

NN	none	+\$0
1M	2 file converters in each file drawer	+\$25
C51	storage organizer including hanging file holder bin, utility tray and two containers <input type="checkbox"/> A	+\$120

For box/box/file (S)

NN	none	+\$0
2M	drawer divider in box drawers, 2 file converters in file drawer	+\$25
3M	drawer divider in one box drawer, pencil tray in one box drawer, 2 file converters in file drawer	+\$25
C51	storage organizer including hanging file holder bin, utility tray and two containers <input type="checkbox"/> A	+\$120

W-Pull Wardrobe Cabinet

LW380.

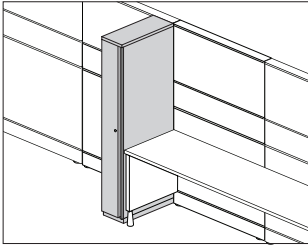

Tu® Metal Storage

Product Information

Description

This single wardrobe attaches to a Canvas frame, another tower or cabinet, or an architectural wall. It has a smooth-steel case, an integrated pull, and recessed base with 1" leveling glides. The interior is available with a coat rod or coat hook.

Actual cabinet height is 41", 45", 56", or 67".

Notes

Wardrobe cannot be used freestanding. It must be anchored to another tower or cabinet, or be attached to a frame or architectural wall.

For keyed-alike locks, order lock plugs separately. See Keyed-Alike Information in Appendices.

Dimensions

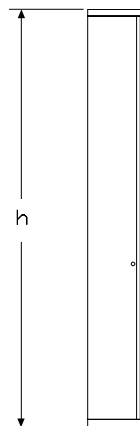
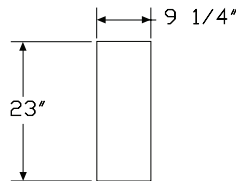

Specification Information

Step 1.

LW380.

Step 2. Height

42	42" high
46	46" high
57	57" high
68	68" high

Step 3. Configuration

L	left-hinged door
R	right-hinged door

Prices for Steps 1-3.

	L	R
LW380.42	\$1017	1017
46	\$1054	1054
57	\$1092	1092
68	\$1131	1131

Step 4. Attachment

F8	Canvas frame attachment	+\$0
F5	tower/cabinet attachment	+\$0

Step 5. Paint/Steel Type

SS	smooth paint on smooth steel	+\$0
XS	textured paint on smooth steel	+\$0

Step 6. Surface Finish

For smooth paint on smooth steel (SS)

8Q	folkstone grey	+\$0
98	studio white	+\$0
BU	black umber	+\$0
CN	metallic champagne	+\$100
EH	metallic bronze	+\$100
HF	inner tone light	+\$0
LT	light tone	+\$0
LU	soft white	+\$0
MS	metallic silver	+\$100
MT	medium tone	+\$0
SG	slate grey	+\$0
WL	sandstone	+\$0

W-Pull Wardrobe Cabinet *continued*

Sand Texture Paint		
<i>For textured paint on smooth steel (XS)</i>		
98	studio white	+\$0

Bright Sand Texture Paint		
<i>For textured paint on smooth steel (XS)</i>		
91	white	+\$0
CL	cool grey neutral	+\$0
G1	graphite	+\$0
WN	warm grey neutral	+\$0

Step 7. Interior		
CR	coat rod	+\$15
CH	coat hook	+\$15

Step 8. Lock		
KA	keyed alike	+\$0
KC	keyed differently, chrome	+\$0
KD	keyed differently, black	+\$0

V-Pull Wardrobe Cabinet

LV380.

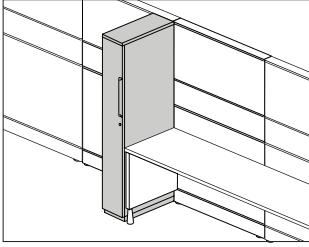

Tu® Metal Storage

Product Information

Description

This single wardrobe attaches to a Canvas frame, another tower or cabinet, or an architectural wall. It has a smooth-steel case, a recessed pull, and recessed base with 1" leveling glides. The interior is available with a coat rod or coat hook.

Actual cabinet height is 41", 45", 56", or 67".

Notes

Wardrobe cannot be used freestanding. It must be anchored to another tower or cabinet, or be attached to a frame or architectural wall.

For keyed-alike locks, order lock plugs separately. See Keyed-Alike Information in Appendices.

Dimensions

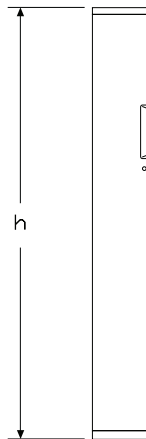
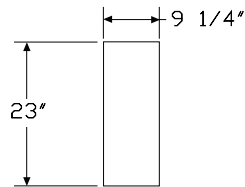

Specification Information

Step 1.

LV380.

Step 2. Height

42	42" high
46	46" high
57	57" high
68	68" high

Step 3. Configuration

L	left-hinged door
R	right-hinged door

Prices for Steps 1-3.

		L	R
LV380. 42		\$1016	1016
	46	\$1052	1052
	57	\$1089	1089
	68	\$1127	1127

Step 4. Attachment

F8	Canvas frame attachment	+\$0
F5	tower/cabinet attachment	+\$0

Step 5. Paint/Steel Type

SS	smooth paint on smooth steel	+\$0
XS	textured paint on smooth steel	+\$0

Step 6. Surface Finish

For smooth paint on smooth steel (SS)

8Q	folkstone grey	+\$0
98	studio white	+\$0
BU	black umber	+\$0
CN	metallic champagne	+\$100
EH	metallic bronze	+\$100
HF	inner tone light	+\$0
LT	light tone	+\$0
LU	soft white	+\$0
MS	metallic silver	+\$100
MT	medium tone	+\$0
SG	slate grey	+\$0
WL	sandstone	+\$0

V-Pull Wardrobe Cabinet *continued*

Sand Texture Paint
For textured paint on smooth steel (XS)

98	studio white	+\$0
-----------	--------------	------

Bright Sand Texture Paint
For textured paint on smooth steel (XS)

91	white	+\$0
CL	cool grey neutral	+\$0
G1	graphite	+\$0
WN	warm grey neutral	+\$0

Step 7. Interior

CR	coat rod	+\$15
CH	coat hook	+\$15

Step 8. Lock

KA	keyed alike	+\$0
KC	keyed differently, chrome	+\$0
KD	keyed differently, black	+\$0

Tu® Storage Tower Attachment Bracket LG692

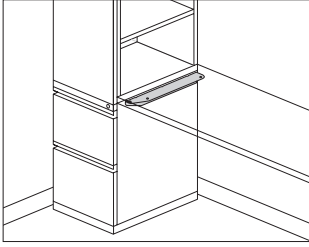

Tu® Metal Storage

Product Information

Description

This bracket attaches to the side of a Tu Metal storage tower to support 1 end of a 24" deep surface, eliminating the need for a support leg or cantilever. Finish is black. Attachment hardware included.

Notes

Bracket must attach to the pedestal side of a metal storage tower.
 Bracket does not provide support for a panel or frame.

Dimensions

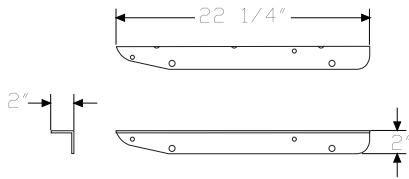

Specification Information

Step 1.

LG692

\$41

File Drawer Organizer

LG901

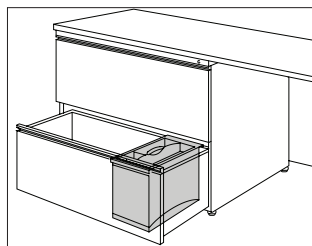

Product Information

Description

This 2-sectioned organizer fits into any file drawer arranged for letter-size filing. The removable top section stores computer disks and other small items. The bottom section stores larger items or can be divided into 3 compartments; it includes 2 vertical dividers. Finish is black umber.

Dimensions

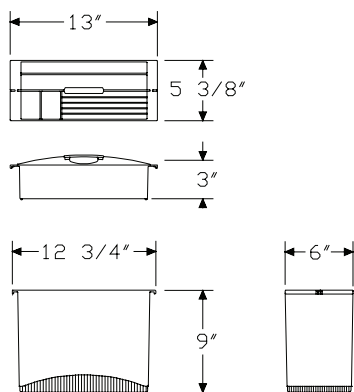

Specification Information

Step 1.

LG901

\$77

Drawer Divider, Tu® Pedestal

LG903.

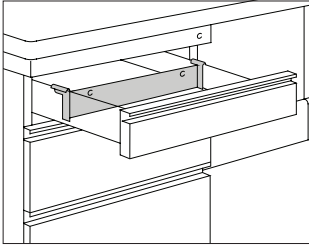

Tu® Metal Storage

Product Information

Description

This adjustable divider is used in a pencil or box drawer. Finish is black umber.

Notes

Divider can be used in the following products:

- 5000 Series furniture with B- and F-pull pedestals
- Tu® Q-, R-, T-, V-, and W-pull pedestals
- Tu storage towers

Dimensions

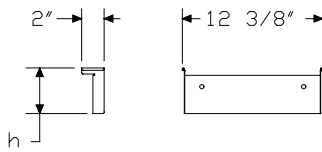

Specification Information

Step 1.

LG903.

Step 2. Usage

- 3** for pencil drawer
- 6** for box drawer

Prices for Steps 1-2.

LG903. 3	\$16
6	\$17

Stationery Divider, Tu® Pedestal LG905

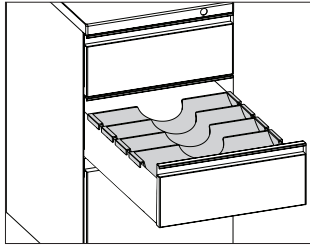

Product Information

Description

These 4 removable dividers are used in box drawers. Finish is black umber.

Notes

Dividers can be used in the following products:

- 5000 Series furniture with B- and F-pull pedestals
- Tu® Q-, R-, T-, V-, and W-pull pedestals
- Tu storage towers

Dimensions

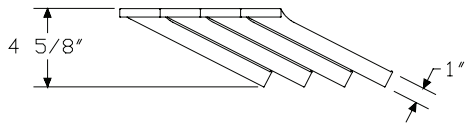

Specification Information

Step 1.

LG905

\$55

Tu® Metal Storage

Utility Tray, Tu® Pedestal

LG906

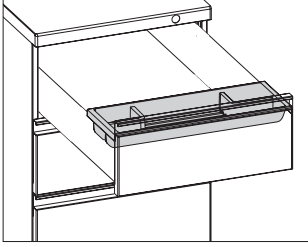

Tu® Metal Storage

Product Information

Description

This sectioned tray stores pencils and small items in a pencil or box drawer. Finish is black umber.

Notes

Tray can be used in the following products:

- 5000 Series furniture with B- and F-pull pedestals
- Tu® Q-, R-, T-, V-, and W-pull pedestals
- Tu storage towers

Dimensions

Specification Information

Step 1.

LG906

\$20

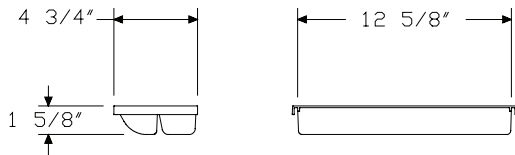

File Converter, Tu®

LG907

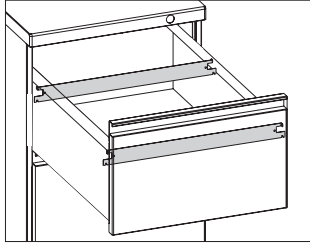

Product Information

Description

These black umber bars convert a file drawer to hold letter-, legal-, and A4-size side-to-side hanging files. 2 converters are used per drawer. Package contains 4.

Notes

- Converters can be used in the following products:
- 5000 Series furniture with B- and F-pull pedestals
 - Tu® Q-, R-, T-, V-, and W-pull pedestals
 - Tu storage towers

Dimensions

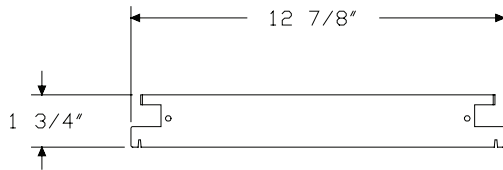

Specification Information

Step 1.

LG907

\$28

Tu® Metal Storage

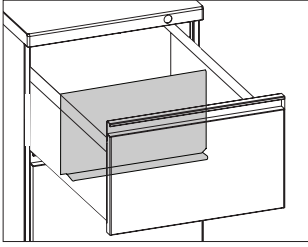

Tu® Metal Storage

Product Information

Description

These compressors lock into slots in the bottom of a pedestal file drawer to divide non-hanging files. Finish is black umber. Package contains 4.

Notes

Compressors can be used in the following products:

- 5000 Series furniture with B- and F-pull pedestals
- Tu® Q-, R-, T-, V-, and W-pull pedestals
- Tu storage towers

Dimensions

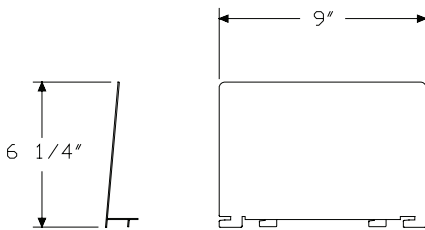

Specification Information

Step 1.

LG908

\$46

Bar-Pull Storage Case

LK400D
LK400L

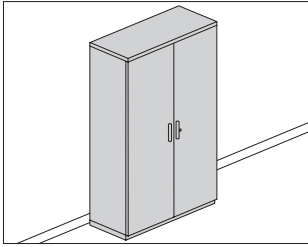

Product Information

Description

This freestanding storage case is smooth-steel with hinged doors that open to 110° and has applied metal bar pulls. It includes 1 or more shelves, depending on height. Shelves adjust in 1/4" increments. All bases have 3/4" leveling glides. Available in 3 widths and 4 heights. Actual case depth is 19 3/8". Actual width is 29 1/2", 35 1/2", or 41 1/2".

Notes

The following chart shows the number of adjustable shelves in each storage case and vertical clearance between shelves when evenly spaced:

Height—Shelves—Bottom space—Mid-space—Top space

26" h (27 1/4" actual)—1 shelf—11 7/8"—n/a—10 1/2"

38" h (39 1/8" actual)—2 shelves—11 7/8"—12 5/8"—8 7/8"

51" h (51 1/2" actual)—3 shelves—11 7/8"—(2) 12 5/8"—7 1/2"

64" h (64 7/8" actual)—4 shelves—11 7/8"—(3) 12 5/8"—7 3/8"

Coat rod (option CR) may be specified in place of shelves.

Coat rod option does not allow shelves to be added later.

Dimensional illustrations do not include all possible configurations.

Order additional storage shelf (LG940.) separately.

For keyed-alike locks, order lock plugs separately. See Keyed-Alike Information in Appendices.

Dimensions

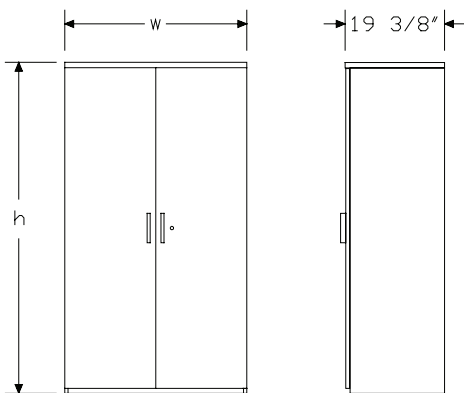

Specification Information

Step 1.

LK400

Step 2. Front Material

- D.** painted metal front
- L.** laminate front

Step 3. Width

- 30** 30" wide
- 36** 36" wide
- 42** 42" wide

Step 4. Height

- 26** 26" high
- 38** 38" high
- 51** 51" high
- 64** 64" high

Prices for Steps 1-4.

	26	38	51	64
LK400D. 30	\$973	1162	1490	1657
36	\$1102	1313	1609	1789
42	\$1245	1484	1739	1934
LK400L. 30	\$1119	1336	1714	1906
36	\$1267	1510	1850	2057
42	\$1432	1707	2000	2224

Step 5. Paint/Steel Type

- SS** smooth paint on smooth steel +\$0
- XS** textured paint on smooth steel +\$0

Step 6. Surface Finish

For smooth paint on smooth steel (SS)

- 8Q** folkstone grey +\$0
- 98** studio white +\$0
- BU** black amber +\$0
- HF** inner tone light +\$0
- LT** light tone +\$0
- LU** soft white +\$0
- MT** medium tone +\$0
- SG** slate grey +\$0
- WL** sandstone +\$0

Bar-Pull Storage Case *continued*

Tu® Metal Storage

For smooth paint on smooth steel (SS)

CN	metallic champagne	+\$65
EH	metallic bronze	+\$65
MS	metallic silver	+\$65

Sand Texture Paint

For textured paint on smooth steel (XS)

98	studio white	+\$0
-----------	--------------	------

Bright Sand Texture Paint

For textured paint on smooth steel (XS)

91	white	+\$0
CL	cool grey neutral	+\$0
G1	graphite	+\$0
WN	warm grey neutral	+\$0

Step 7. Interior

For 64" high (64)

CR	coat rod	-\$148
NS4	4 shelves total	+\$0

Step 8. Lock

KA	keyed alike	+\$0
KC	keyed differently, chrome	+\$0
KD	keyed differently, black	+\$0

Step 9. Pull Finish

79	green apple <input type="checkbox"/> A	+\$15
8Q	folkstone grey	+\$0
91	white	+\$0
98	studio white	+\$0
CN	metallic champagne <input type="checkbox"/> A	+\$0
G1	graphite <input type="checkbox"/> A	+\$0
MS	metallic silver	+\$0
MY3	yellow oxide <input type="checkbox"/> A	+\$15
RO	red <input type="checkbox"/> A	+\$15
TRQ	turquoise <input type="checkbox"/> A	+\$15
WL	sandstone <input type="checkbox"/> A	+\$0

Arc Pull Storage Case

LQ400D
LQ400L

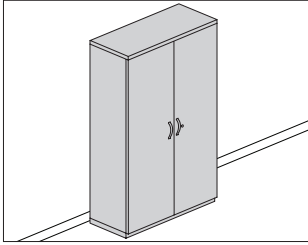

Product Information

Description

This freestanding storage case is smooth-steel with hinged doors that open to 110° and has applied metal arc pulls. It includes 1 or more shelves, depending on height. Shelves adjust in 1/4" increments. All bases have 3/4" leveling glides. Available in 3 widths and 4 heights. Actual case depth is 19 3/8". Actual width is 29 1/2", 35 1/2", or 41 1/2".

Notes

Pull design conforms to guidelines of Americans with Disabilities Act (ADA).

The following chart shows the number of adjustable shelves in each storage case and vertical clearance between shelves when evenly spaced:

Height—Shelves—Bottom space—Mid-space—Top space

26" h (27 1/4" actual)—1 shelf—11 7/8"—n/a—10 1/2"

38" h (39 1/8" actual)—2 shelves—11 7/8"—12 5/8"—8 7/8"

51" h (51 1/2" actual)—3 shelves—11 7/8"—(2) 12 5/8"—7 1/2"

64" h (64 7/8" actual)—4 shelves—11 7/8"—(3) 12 5/8"—7 3/8"

Coat rod (option CR) may be specified in place of shelves.

Coat rod option does not allow shelves to be added later.

Dimensional illustrations do not include all possible configurations.

Order additional storage shelf (LG940.) separately.

For keyed-alike locks, order lock plugs separately. See Keyed-Alike Information in Appendices.

Dimensions

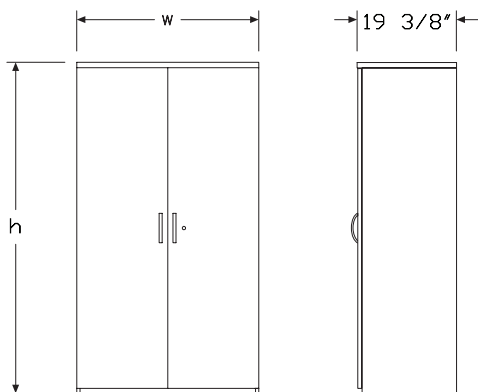

Specification Information

Step 1.

LQ400

Step 2. Front Material

- D.** painted metal front
- L.** laminate front

Step 3. Width

- 30** 30" wide
- 36** 36" wide
- 42** 42" wide

Step 4. Height

- 26** 26" high
- 38** 38" high
- 51** 51" high
- 64** 64" high

Prices for Steps 1-4.

		26	38	51	64
LQ400D.	30	\$973	1162	1490	1657
	36	\$1102	1313	1609	1789
	42	\$1245	1484	1739	1934
LQ400L.	30	\$1119	1336	1714	1906
	36	\$1267	1510	1850	2057
	42	\$1432	1707	2000	2224

Step 5. Paint/Steel Type

- SS** smooth paint on smooth steel +\$0
- XS** textured paint on smooth steel +\$0

Arc Pull Storage Case *continued*

Tu® Metal Storage

Step 6. Surface Finish

For smooth paint on smooth steel (SS)

8Q	folkstone grey	+\$0
98	studio white	+\$0
BU	black umber	+\$0
CN	metallic champagne	+\$65
EH	metallic bronze	+\$65
HF	inner tone light	+\$0
LT	light tone	+\$0
LU	soft white	+\$0
MS	metallic silver	+\$65
MT	medium tone	+\$0
SG	slate grey	+\$0
WL	sandstone	+\$0

Sand Texture Paint

For textured paint on smooth steel (XS)

98	studio white	+\$0
-----------	--------------	------

Bright Sand Texture Paint

For textured paint on smooth steel (XS)

91	white	+\$0
CL	cool grey neutral	+\$0
G1	graphite	+\$0
WN	warm grey neutral	+\$0

Step 7. Interior

For 64" high (64)

CR	coat rod	-\$148
NS4	4 shelves total	+\$0

Step 8. Lock

KA	keyed alike	+\$0
KC	keyed differently, chrome	+\$0
KD	keyed differently, black	+\$0

Step 9. Pull Finish

NH	brushed nickel	+\$0
NK	black nickel	+\$0

W-Pull Storage Case

LW400.

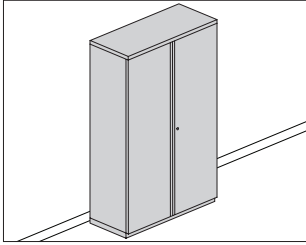

Product Information

Description

This freestanding storage case is smooth-steel with hinged doors that open to 110° and has integrated pulls. It includes 1 or more shelves, depending on height. Shelves adjust in 1/4" increments. All bases have 3/4" leveling glides. Available in 3 widths and 4 heights.
Actual case depth is 19 3/8". Actual width is 29 1/2", 35 1/2", or 41 1/2".

Notes

The following chart shows the number of adjustable shelves in each storage case and vertical clearance between shelves when evenly spaced:

Height—Shelves—Bottom space—Mid-space—Top space
26" h (27 1/4" actual)—1 shelf—11 7/8"—n/a—10 1/2"
38" h (39 1/8" actual)—2 shelves—11 7/8"—12 5/8"—8 7/8"
51" h (51 1/2" actual)—3 shelves—11 7/8"—(2) 12 5/8"—7 1/2"
64" h (64 7/8" actual)—4 shelves—11 7/8"—(3) 12 5/8"—7 3/8"

Coat rod (option CR) may be specified in place of shelves.

Coat rod option does not allow shelves to be added later.

Dimensional illustrations do not include all possible configurations.

Order additional storage shelf (LG940.) separately.

For keyed-alike locks, order lock plugs separately. See Keyed-Alike Information in Appendices.

Dimensions

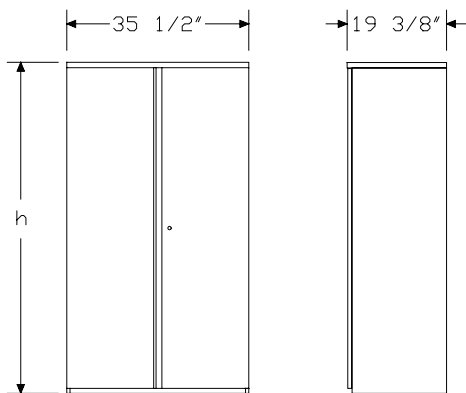

Specification Information

Step 1.

LW400.

Step 2. Width

30	30" wide
36	36" wide
42	42" wide

Step 3. Height

26	26" high
38	38" high
51	51" high
64	64" high

Prices for Steps 1-3.

	26	38	51	64
LW400. 30	\$961	1166	1353	1692
36	\$1059	1261	1547	1719
42	\$1194	1426	1669	1858

Step 4. Paint/Steel Type

SS	smooth paint on smooth steel			+\$0
XS	textured paint on smooth steel			+\$0

Step 5. Surface Finish

For smooth paint on smooth steel (SS)

8Q	folkstone grey	+\$0
98	studio white	+\$0
BU	black umber	+\$0
CN	metallic champagne	+\$65
EH	metallic bronze	+\$65
HF	inner tone light	+\$0
LT	light tone	+\$0
LU	soft white	+\$0
MS	metallic silver	+\$65
MT	medium tone	+\$0
SG	slate grey	+\$0
WL	sandstone	+\$0

Sand Texture Paint

For textured paint on smooth steel (XS)

98	studio white	+\$0
-----------	--------------	------

W-Pull Storage Case *continued*

Tu® Metal Storage

Bright Sand Texture Paint
For textured paint on smooth steel (XS)

91	white	+\$0
CL	cool grey neutral	+\$0
G1	graphite	+\$0
WN	warm grey neutral	+\$0

Step 6. Interior
For 64" high (64)

CR	coat rod	-\$148
NS4	4 shelves total	+\$0

Step 7. Lock

KA	keyed alike	+\$0
KC	keyed differently, chrome	+\$0
KD	keyed differently, black	+\$0

V-Pull Storage Case

LV400.

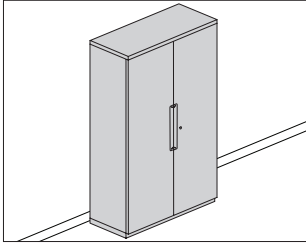

Product Information

Description

This freestanding storage case is smooth-steel with hinged doors that open to 110° and has recessed pulls. It includes 1 or more shelves, depending on height. Shelves adjust in 1/4" increments. All bases have 3/4" leveling glides. Available in 3 widths and 4 heights.
Actual case depth is 19 3/8". Actual width is 29 1/2", 35 1/2", or 41 1/2".

Notes

The following chart shows the number of adjustable shelves in each storage case and vertical clearance between shelves when evenly spaced:

Height—Shelves—Bottom space—Mid-space—Top space
 26" h (27 1/4" actual)—1 shelf—11 7/8"—n/a—10 1/2"
 38" h (39 1/8" actual)—2 shelves—11 7/8"—12 5/8"—8 7/8"
 51" h (51 1/2" actual)—3 shelves—11 7/8"—(2) 12 5/8"—7 1/2"
 64" h (64 7/8" actual)—4 shelves—11 7/8"—(3) 12 5/8"—7 3/8"

Coat rod (option CR) may be specified in place of shelves.

Coat rod option does not allow shelves to be added later.

Dimensional illustrations do not include all possible configurations.

Order additional storage shelf (LG940.) separately.

For keyed-alike locks, order lock plugs separately. See Keyed-Alike Information in Appendices.

Dimensions

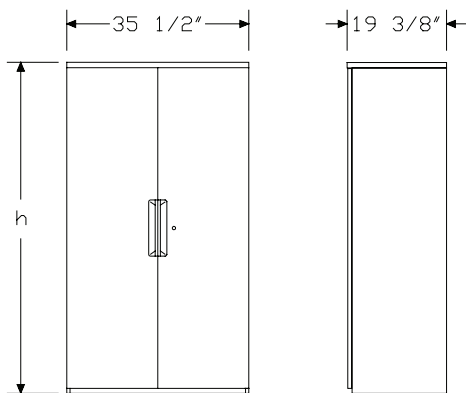

Specification Information

Step 1.

LV400.

Step 2. Width

30	30" wide
36	36" wide
42	42" wide

Step 3. Height

26	26" high
38	38" high
51	51" high
64	64" high

Prices for Steps 1-3.

	26	38	51	64
LV400. 30	\$961	1167	1354	1693
36	\$1057	1262	1548	1721
42	\$1196	1426	1671	1858

Step 4. Paint/Steel Type

SS	smooth paint on smooth steel			+\$0
XS	textured paint on smooth steel			+\$0

Step 5. Surface Finish

For smooth paint on smooth steel (SS)

8Q	folkstone grey	+\$0
98	studio white	+\$0
BU	black umber	+\$0
CN	metallic champagne	+\$65
EH	metallic bronze	+\$65
HF	inner tone light	+\$0
LT	light tone	+\$0
LU	soft white	+\$0
MS	metallic silver	+\$65
MT	medium tone	+\$0
SG	slate grey	+\$0
WL	sandstone	+\$0

Sand Texture Paint

For textured paint on smooth steel (XS)

98	studio white	+\$0
-----------	--------------	------

V-Pull Storage Case *continued*

Tu® Metal Storage

Bright Sand Texture Paint

For textured paint on smooth steel (XS)

91	white	+\$0
CL	cool grey neutral	+\$0
G1	graphite	+\$0
WN	warm grey neutral	+\$0

Step 6. Interior

For 64" high (64)

CR	coat rod	-\$148
NS4	4 shelves total	+\$0

Step 7. Lock

KA	keyed alike	+\$0
KC	keyed differently, chrome	+\$0
KD	keyed differently, black	+\$0

Storage Case Shelf

LG940.

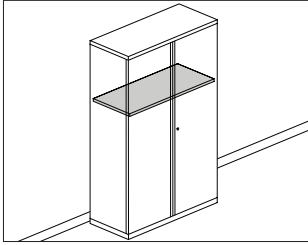

Product Information

Description

This smooth-steel shelf fits into a 20"-deep Tu® storage case or overfile to provide additional shelf storage. Available in 3 widths. Shelf attachment clips included.

Actual shelf depth is 14⁷/₈". Actual shelf width is 27¹/₂", 33¹/₂", or 39¹/₂".

Dimensions

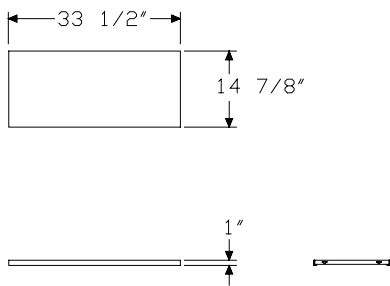

Specification Information

Step 1.

LG940.

Step 2. Width

30	30" wide
36	36" wide
42	42" wide

Prices for Steps 1-2.

LG940. 30	\$54
36	\$63
42	\$73

Step 3. Paint/Steel Type

SS	smooth paint on smooth steel	+\$0
XS	textured paint on smooth steel	+\$0

Step 4. Surface Finish

For smooth paint on smooth steel (SS)

98	studio white	+\$0
8Q	folkstone grey	+\$0
BU	black umber	+\$0
HF	inner tone light	+\$0
LT	light tone	+\$0
LU	soft white	+\$0
MT	medium tone	+\$0
SG	slate grey	+\$0
WL	sandstone	+\$0
CN	metallic champagne	+\$5
EH	metallic bronze	+\$5
MS	metallic silver	+\$5

Sand Texture Paint

For textured paint on smooth steel (XS)

98	studio white	+\$0
-----------	--------------	------

Bright Sand Texture Paint

For textured paint on smooth steel (XS)

91	white	+\$0
CL	cool grey neutral	+\$0
G1	graphite	+\$0
WN	warm grey neutral	+\$0

Bookcase

LG500.

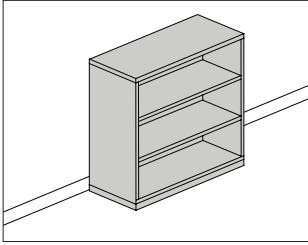

Tu® Metal Storage

Product Information

Description

This freestanding bookcase provides storage and display space. It has a smooth-steel case and adjustable shelves. It includes 1 or more shelves, depending on height. Shelves adjust in 1/4" increments. All bases have 3/4" leveling glides. Available in 3 widths and 4 heights. Actual bookcase depth is 15". Actual width is 29 1/2", 35 1/2", or 41 1/2".

Notes

The following chart shows the number of adjustable shelves in each bookcase and vertical clearance between shelves when evenly spaced:

Height — Shelves — Bottom space — Mid-space — Top space
26" h (27 1/4" actual) — 1 shelf — 11 7/8" — n/a — 10 1/2"
38" h (39 1/8" actual) — 2 shelves — 11 7/8" — 12 5/8" — 8 7/8"
51" h (51 1/2" actual) — 3 shelves — 11 7/8" — (2) 12 5/8" — 7 1/2"
64" h (64 7/8" actual) — 4 shelves — 11 7/8" — (3) 12 5/8" — 7 3/8"

Dimensional illustrations do not include all possible configurations.

Order additional bookcase shelf (LG950.) separately.

Dimensions

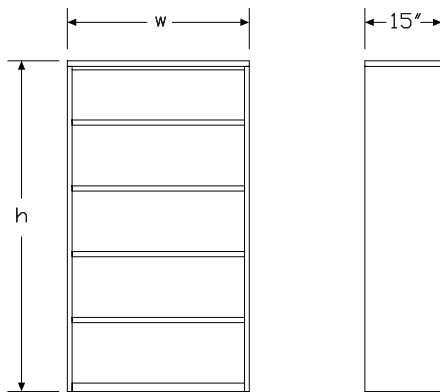

Specification Information

Step 1.

LG500.

Step 2. Width

30	30" wide
36	36" wide
42	42" wide

Step 3. Height

26	26" high
38	38" high
51	51" high
64	64" high

Prices for Steps 1-3.

	26	38	51	64
LG500. 30	\$856	913	968	1024
36	\$978	1033	1088	1144
42	\$1096	1152	1209	1264

Step 4. Paint/Steel Type

SS	smooth paint on smooth steel	+\$0
XS	textured paint on smooth steel	+\$0

Step 5. Surface Finish

For smooth paint on smooth steel (SS)

8Q	folkstone grey	+\$0
98	studio white	+\$0
BU	black umber	+\$0
CN	metallic champagne	+\$55
EH	metallic bronze	+\$55
HF	inner tone light	+\$0
LT	light tone	+\$0
LU	soft white	+\$0
MS	metallic silver	+\$55
MT	medium tone	+\$0
SG	slate grey	+\$0
WL	sandstone	+\$0

Sand Texture Paint

For textured paint on smooth steel (XS)

98	studio white	+\$0
-----------	--------------	------

Bookcase *continued*

Bright Sand Texture Paint

For textured paint on smooth steel (XS)

91	white	+\$0
CL	cool grey neutral	+\$0
G1	graphite	+\$0
WN	warm grey neutral	+\$0

Bookcase Shelf

LG950.

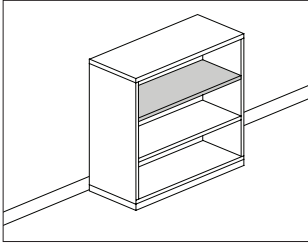

Tu® Metal Storage

Product Information

Description

This smooth-steel shelf fits into a 15"-deep Tu® bookcase to provide additional shelf storage. Available in 3 widths. Shelf attachment clips included.

Actual shelf depth is 12³/₄".

Dimensions

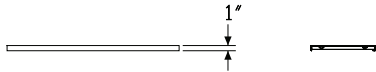
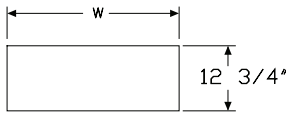

Specification Information

Step 1.

LG950.

Step 2. Width

30	30" wide
36	36" wide
42	42" wide

Prices for Steps 1-2.

LG950. 30	\$51
36	\$61
42	\$71

Step 3. Paint/Steel Type

SS	smooth paint on smooth steel	+\$0
XS	textured paint on smooth steel	+\$0

Step 4. Surface Finish

For smooth paint on smooth steel (SS)

8Q	folkstone grey	+\$0
98	studio white	+\$0
BU	black umber	+\$0
CN	metallic champagne	+\$5
EH	metallic bronze	+\$5
HF	inner tone light	+\$0
LT	light tone	+\$0
LU	soft white	+\$0
MS	metallic silver	+\$5
MT	medium tone	+\$0
SG	slate grey	+\$0
WL	sandstone	+\$0

Sand Texture Paint

For textured paint on smooth steel (XS)

98	studio white	+\$0
-----------	--------------	------

Bright Sand Texture Paint

For textured paint on smooth steel (XS)

91	white	+\$0
CL	cool grey neutral	+\$0
G1	graphite	+\$0
WN	warm grey neutral	+\$0

Keyless Lock

MKL-H
 MKL-V
 MKS-H
 MKS-V

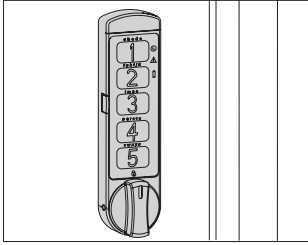

Product Information

Description

This keyless lock replaces an existing cam lock and is available in 2 mode options. Locker mode allows for a temporary code to be entered for each use, and station mode allows for repeated use with the same code. Multiple orientation options allow the keyless lock to be used with a variety of products.

Notes

Replacement battery is a 3-volt lithium CR2032 battery.
 Actual lock dimensions are 3.86"W x 1.00"H x 0.39"D.
 Meridian® standard pull 2600 series, the Tu® metal pedestal, and some Tu metal lateral files will not accommodate the width of the keyless lock.
 Order the following products separately:

- Control key fob (MKL-CKF)
- User key fob (MKL-UKF)

This keyless lock can be found under the Meridian® product line code of MS.

Dimensions

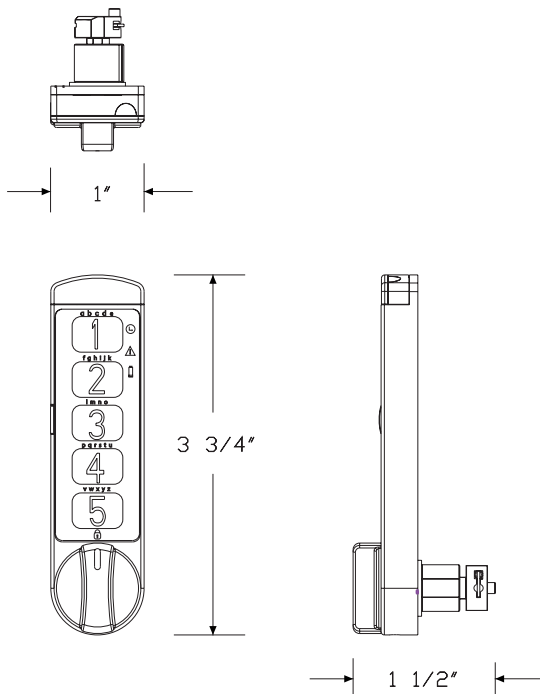

Specification Information

Step 1.

MK

Step 2. Mode

L- locker mode
S- station mode

Step 3. Orientation

HL horizontal, keypad facing left
HR horizontal, keypad facing right
VU vertical, keypad facing up
VD vertical, keypad facing down

Prices for Steps 1-3.

MKL-HL	\$197
MKL-HR	\$197
MKL-VU	\$197
MKL-VD	\$197
MKS-HL	\$197
MKS-HR	\$197
MKS-VU	\$197
MKS-VD	\$197

Step 4. Finish

OI silver <input type="checkbox"/>	+\$0
BK black <input type="checkbox"/>	+\$0

Tu® Keyless Locks

Keyless Lock, Control Key Fob

MKL-C



Product Information

Description
This key fob opens the keyless lock without using the numeric keypad.

Notes

Order the following products separately:

- Keyless lock (MK)
- User key fob (MKL-UKF)

This keyless lock, control key fob can be found under the Meridian® product line code of MS.

Dimensions

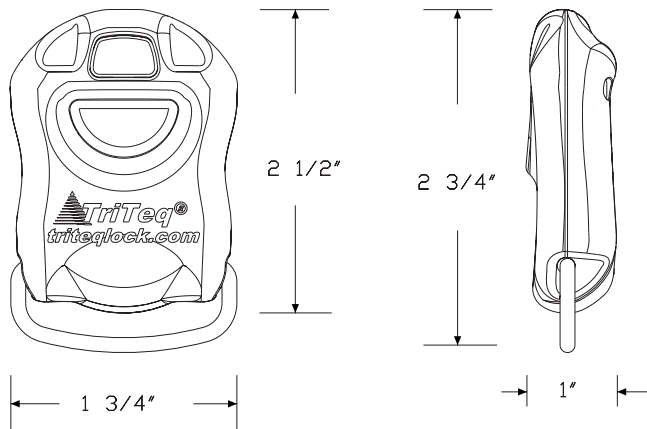

Specification Information

Step 1.
MKL-CKF A \$167

Tu® Keyless Locks

Keyless Lock, User Key Fob

MKL-U



Product Information

Description

This key fob opens the keyless lock without using the numeric keypad.

Notes

Order the following products separately:

- Keyless lock (MK)
- Control key fob (MKL-CKF)

This keyless lock, user key fob can be found under the Meridian® product line code of MS.

Dimensions

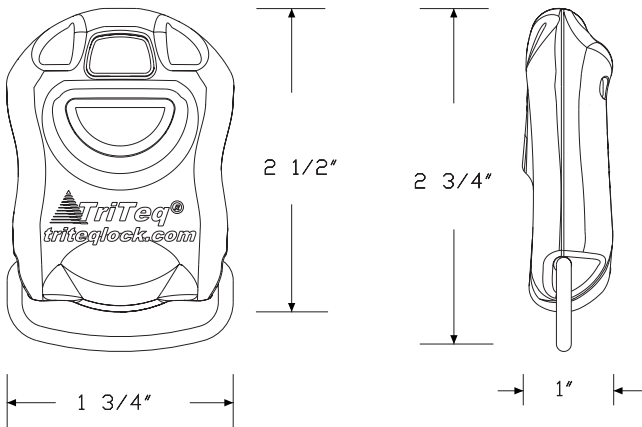

Specification Information

Step 1.

MKL-UKF A

\$167

Index by Product Name

Tu® Storage	
Arc Pull Add-On Overfile	page(s) 85
Arc Pull Freestanding Lateral File	72
Arc Pull Freestanding Pedestal	8
Arc Pull Mobile Pedestal	20
Arc Pull Storage Case	133
Arc Pull Storage Tower	104
Arc Pull Support Pedestal	44
Arc Pull Surface-Attached Pedestal	32
Arc Pull Suspended Pedestal	55
Bar-Pull Add-On Overfile	83
Bar-Pull Freestanding Lateral File	69
Bar-Pull Freestanding Pedestal	5
Bar Pull Mobile Pedestal	17
Bar-Pull Storage Case	131
Bar-Pull Storage Tower	100
Bar Pull Support Pedestal	41
Bar Pull Surface-Attached Pedestal	29
Bar Pull Suspended Pedestal	53
Bookcase	140
Bookcase Shelf	142
Counterweight, Tu® Lateral File	98
Drawer Divider, Tu® Pedestal	126, 64
File Compressor, Tu®	130, 68
File Converter, Tu®	129, 67
File Drawer Organizer	125, 95, 63
Front-to-Back Filing Rail, Tu® Lateral File	94
Keyless Lock	143
Keyless Lock, Control Key Fob	144
Keyless Lock, User Key Fob	145
Label Holders-Snap In and Adhesive	99
Lateral File Add-On Cushion Top	93
Movable Divider, Meridian®, Quadrant® or Tu®	97
Pedestal Add-On Cushion Top	61
Side-to-Side Filing Rail, Tu® Lateral File	96
Stationery Divider, Tu® Pedestal	127, 65
Storage Case Shelf	139
Storage Organizer	62
Tu® File Top	91
Tu® Storage Tower Attachment Bracket	124
Utility Tray, Tu® Pedestal	128, 66
V-Pull Add-On Overfile	89
V-Pull Freestanding Lateral File	79
V-Pull Freestanding Pedestal	14
V-Pull Lateral File, with Open Shelf	81
V-Pull Mobile Pedestal	26
V-Pull Storage Case	137

V-Pull Storage Tower	111
V-Pull Storage Tower, No Wardrobe	117
V-Pull Support Pedestal	50
V-Pull Surface-Attached Pedestal	38
V-Pull Suspended Pedestal	59
V-Pull Wardrobe Cabinet	122
W-Pull Add-On Overfile	87
W-Pull Freestanding Lateral File	75
W-Pull Freestanding Pedestal	11
W-Pull Lateral File, with Open Shelf	77
W-Pull Mobile Pedestal	23
W-Pull Storage Case	135
W-Pull Storage Tower	108
W-Pull Storage Tower, No Wardrobe	114
W-Pull Support Pedestal	47
W-Pull Surface-Attached Pedestal	35
W-Pull Suspended Pedestal	57
W-Pull Wardrobe Cabinet	120

Index by Product Number

9LH5H Label Holders-Snap In and Adhesive	page(s) 99	LQ14D.	
9LH7H		LQ15A. Arc Pull Support Pedestal	44
9M100 Movable Divider, Meridian®, Quadrant® or Tu®	97	LQ15D.	
9M300		LQ20A. Arc Pull Freestanding Lateral File	72
LG500. Bookcase	140	LQ20D.	
LG692 Tu® Storage Tower Attachment Bracket	124	LQ300D Arc Pull Storage Tower	104
LG890. Pedestal Add-On Cushion Top	61	LQ300L	
LG891. Lateral File Add-On Cushion Top	93	LQ310D	
LG901 File Drawer Organizer	125, 95, 63	LQ310L	
LG902. Side-to-Side Filing Rail, Tu® Lateral File	96	LQ400D Arc Pull Storage Case	133
LG903. Drawer Divider, Tu® Pedestal	126, 64	LQ400L	
LG904. Front-to-Back Filing Rail, Tu® Lateral File	94	LQ410D Arc Pull Add-On Overfile	85
LG905 Stationery Divider, Tu® Pedestal	127, 65	LQ410L	
LG906 Utility Tray, Tu® Pedestal	128, 66	LTPL- Tu® File Top	91
LG907 File Converter, Tu®	129, 67	LTPV-	
LG908 File Compressor, Tu®	130, 68	LV100. V-Pull Freestanding Pedestal	14
LG909. Counterweight, Tu® Lateral File	98	LV110. V-Pull Mobile Pedestal	26
LG910. Storage Organizer	62	LV130. V-Pull Suspended Pedestal	59
LG940. Storage Case Shelf	139	LV140. V-Pull Surface-Attached Pedestal	38
LG950. Bookcase Shelf	142	LV150. V-Pull Support Pedestal	50
LK10A. Bar-Pull Freestanding Pedestal	5	LV200. V-Pull Freestanding Lateral File	79
LK10D.		LV260. V-Pull Lateral File, with Open Shelf	81
LK11A. Bar Pull Mobile Pedestal	17	LV300. V-Pull Storage Tower	111
LK11D.		LV310.	
LK13A. Bar Pull Suspended Pedestal	53	LV320. V-Pull Storage Tower, No Wardrobe	117
LK13D.		LV330.	
LK14A. Bar Pull Surface-Attached Pedestal	29	LV380. V-Pull Wardrobe Cabinet	122
LK14D.		LV400. V-Pull Storage Case	137
LK15A. Bar Pull Support Pedestal	41	LV410. V-Pull Add-On Overfile	89
LK15D.		LW100. W-Pull Freestanding Pedestal	11
LK20A. Bar-Pull Freestanding Lateral File	69	LW110. W-Pull Mobile Pedestal	23
LK20D.		LW130. W-Pull Suspended Pedestal	57
LK300D Bar-Pull Storage Tower	100	LW140. W-Pull Surface-Attached Pedestal	35
LK300L		LW150. W-Pull Support Pedestal	47
LK310D		LW200. W-Pull Freestanding Lateral File	75
LK310L		LW260. W-Pull Lateral File, with Open Shelf	77
LK400D Bar-Pull Storage Case	131	LW300. W-Pull Storage Tower	108
LK400L		LW310.	
LK410D Bar-Pull Add-On Overfile	83	LW320. W-Pull Storage Tower, No Wardrobe	114
LK410L		LW330.	
LQ10A. Arc Pull Freestanding Pedestal	8	LW380. W-Pull Wardrobe Cabinet	120
LQ10D.		LW400. W-Pull Storage Case	135
LQ11A. Arc Pull Mobile Pedestal	20	LW410. W-Pull Add-On Overfile	87
LQ11D.		MKL-C Keyless Lock, Control Key Fob	144
LQ13A. Arc Pull Suspended Pedestal	55	MKL-H Keyless Lock	143
LQ13D.		MKL-U Keyless Lock, User Key Fob	145
LQ14A. Arc Pull Surface-Attached Pedestal	32	MKL-V Keyless Lock	143

Index by Product Number *continued*



Index: Product Number

MKS-H
MKS-V

20-Day or Less/Assigned Lead-Time Order Information

20-Day or Less and Assigned Lead-Time Programs

20-day or less and assigned lead-time products are designed for established Herman Miller dealers with pre-approved credit.

Products are distributed from multiple manufacturing facilities across the United States. All products and options not designated by an Assigned Lead-Time icon  will ship in 20 business days or less after being acknowledged by Herman Miller. Products and options designated by an  are on the assigned lead-time program and will ship in 20 days, less than 20 days, or more than 20 days from order acknowledgement.

Ordering Procedure

Please place orders through Order Manager. If this is not available to you, place orders through mail or fax. Verbal purchase orders will not be accepted.

Order Entry fax number for Passage®, 5000 Series, and Meridian®
Filing and Storage: (616) 846 9236.

Order Entry fax number for all other products:
(616) 654 3085.

For more information, contact your Customer Care representative at:
(866) 854 3048 EXT 3400.

Shipments and Delivery

Per Herman Miller Terms and Conditions.

Changes and Cancellation

Per Herman Miller Terms and Conditions.



Keyed-Alike Information

Keyed-Alike Locks

All components with locks may be specified keyed alike. Products with keyed-alike locks will be shipped with lock chassis installed.

Installation of lock cylinders will be on-site according to instructions provided. Herman Miller, Inc., will not be responsible for lock cylinder installation.

When specifying product keyed-alike, include separate lines on your order for the lock cylinders.

For Action Office®, Ethospace®, Passage®, Quadrant®, Resolve®, and Supplemental products, list cylinder part number and key number (232092-XXX); select a key number (or numbers) between 226 and 427, excluding numbers 408 and 412.

The following products require a different lock cylinder part number. Specify UKY001-XXX for these products only; select a key number (or numbers) between 226 and 427, excluding numbers 408 and 412.

- A3013.
- A3053.
- G5180.
- G5181.
- G5280.

The keys provided in 232092-XXX and UKY001-XXX kits work with either cylinder type, provided the key numbers match.

For Tu® Storage, Canvas Office Landscape®, 5000 Series, and Meridian® Storage, see the following charts.

Keyed-alike locks are field installed.

To order keyed-alike locks for Action Office® Series 1 and 2 door panels, please contact Customer Care.

A master key can be used to open any lock on an attached or freestanding component. In addition, a removal key or lock change tool is required to remove lock plugs. Customers interested in ordering master keys, removal keys, or lock change tools should contact Customer Care.

For Canvas overhead and lower storage units, specify as follows:

Specification Code	Part Number	Color	Lock Series
KA	1B2JK7-XXX ¹	chrome	UM series 226-427

For Meridian Storage, Tu Storage, and 5000 Series desk components with pedestals, specify as follows:

Specification Code	Key Number	Color	Lock Series
KA	232092-XXX ¹	black	UM series 226-427
KA	1B2JK7-XXX ¹	chrome	UM series 226-427

For 5000 Series flipper door unit with bezel or credenza storage cabinet with bezel, specify as follows:

Specification Code	Key Number	Color	Lock Series
KA	232092-XXX ¹	black	UM series 226-427

Key Number:

XXX¹ = a key number between 226 and 427 (excluding 408 and 412)



Customer's Own Material/ Customer's Own Leather Order Information — Cushion Tops

Customer's Own Material/Customer's Own Leather

Program Overview

The Customer's Own Material (COM) and Customer's Own Leather (COL) program gives you the option of using textiles other than those listed. Herman Miller will test textiles for application to Herman Miller products and will process orders for those with approved COM/COL textiles only. COM/COL are assigned lead time textiles.

Omni lists an overview of fabrics and leathers that have been tested and indicates whether or not they were approved for application to Herman Miller products.

Specific information on the terms and conditions, testing, approval, and ordering process for COM/COL is listed below. Questions about the COM/COL program and requests for assistance may be directed to your COM representative at:

(616) 654 3400

(866) 854 3048 EXT 6543400

Customer's Own Material/Customer's Own Leather Warranty

Herman Miller does not warrant COM/COL textiles. COM/COL textiles are tested for application only; they are not tested for performance. The Herman Miller warranty does apply to the underlying products.

Suppliers of COM/COL textiles are responsible for color consistency within commercial tolerances, UV stability, and resistance to soiling and perspiration.

Customer's Own Material/Customer's Own Leather Pricing

COM is a Category 1 fabric. There are no application charges for COM fabrics. COL is a Category 7 textile; refer to prices on specific products to determine the application charge.

Ordering and payment for COM/COL textile yardage are the responsibility of the customer and the textile supplier.

If desired, Herman Miller will purchase COM textiles directly from True Textiles, C.F. Stinson, Luna Textiles, Maharam, and Momentum Textiles to simplify ordering and shipment. For this service, refer to the Supplier Connection program.

Application Note

Herman Miller does not guarantee that Customer's Own Material (COM) fabric patterns will align across panels/tiles or from one screen to the next. We also do not guarantee that COM fabric designs will be positioned consistently in the same location across several panels, tiles, or screens.

Textile Approval

1. Select a COM/COL textile.
2. If your textile is not listed on Omni, obtain a test number from a COM representative at (616) 654 3400. You can also submit your request within Omni. Please have the following information ready before calling: textile name, number, pattern, and the product you will apply it to.
3. Herman Miller will notify you of approval or disapproval within 4 days from receipt of the test yardage.

Customer's Own Material/ Customer's Own Leather Order Information — Cushion Tops

continued

Ordering Products with COM/COL

1. Refer to the specific products to determine the yardage required for COM/COL textiles.
2. If your textile is not listed on Omni, call a COM representative at (616) 654 3400 or (866) 854 3048 EXT 6543400. The representative will assign an identification number for your textile (ID#) and will verify yardage requirements for your order. Yardage requirements are based on directional, 54"-wide textiles. Additional yardage may be needed due to the unique characteristics of a textile.
3. Enter your order on Order Manager in Omni.
4. Upon receipt of your purchase order, Herman Miller will send you a PO acknowledgment.
5. Arrangements must be made for the textiles to be shipped from the supplier to Herman Miller for application to the seating products. See Omni for shipping procedures and current shipping addresses or contact a COM representative at (616) 654 3400 or (866) 854 3048 EXT 6543400.

Products will be scheduled for production when COM/COL textiles are received at Herman Miller. Standard lead times in effect at that time will apply.

Note: If textiles are to be purchased directly by Herman Miller through the Supplier Connection program, Herman Miller will handle the ordering and shipping process and will schedule your order for production upon receipt of your purchase order (dependent on textile availability). Refer to the Supplier Connection program for more information.

Supplier Connection

Program Overview

The Supplier Connection program is a service offered by Herman Miller to purchase approved COM textiles directly from True Textiles, C.F. Stinson, Luna Textiles, Maharam, and Momentum Textiles. When you select a textile through this program, Herman Miller will facilitate the ordering, scheduling, and shipment of the textile directly with the supplier.

Suppliers included in the Supplier Connection program keep an active inventory of textiles that are pre-approved for application to Herman Miller products. Pre-approval applies only to the suitability of a textile for manufacturing and application to a Herman Miller product. Omni provides an overview of fabrics that have been tested and indicates whether or not they were approved for application to Herman Miller products.

Specific information on the terms and conditions, testing, approval, and ordering process for the Supplier Connection program is listed below. Questions and requests for assistance may be directed to your COM representative at:

(616) 654 3400
(866) 854 3048 EXT 6543400

Supplier Connection Warranty

Textiles purchased by Herman Miller through the Supplier Connection program are COM and are not warranted by Herman Miller. COM textiles are tested for application only; they are not tested for performance. The Herman Miller warranty does apply to the underlying products.

Suppliers of COM textiles are responsible for color consistency within commercial tolerances, UV stability, and resistance to soiling and perspiration.

Customer's Own Material/ Customer's Own Leather Order Information — Cushion Tops

continued

Supplier Connection Pricing

Textiles purchased by Herman Miller through the Supplier Connection program are COM. COM is a Category 1 fabric. There are no application charges for COM fabrics.

Payment for textiles purchased by Herman Miller through the Supplier Connection program is the responsibility of the customer or dealer. Herman Miller will invoice the order at the supplier's prices published at the time of the order.

Textile Approval

1. Refer to Omni to identify the approval status of the textile. If your textile is not listed, contact the COM Department to request testing for application to Herman Miller products.
2. Herman Miller will notify you of approval or disapproval in approximately 4 days from receipt of the test yardage. If the textile is approved, it will be assigned a COM identification number.

Ordering Products with Supplier Connection COM

1. Identify and include the following information on your purchase order:
 - Product number and option
 - Herman Miller's COM identification number
2. Enter your order on Order Manager in Omni.
3. Upon receipt of the purchase order, Herman Miller will process your order and send you a PO acknowledgment. Herman Miller will determine the yardage required to produce your product and will order and schedule for delivery the required textile. Standard lead times in effect at the time the textile is allocated at the supplier will apply to products ordered through this program.



For more information about our products and services or to see a list of dealers, please visit us at HermanMiller.com or call (800) 851 1196.

© 2018 Herman Miller, Inc., Zeeland, Michigan

® **HermanMiller**, ●, Action Office, Aeron, Aside, Avive, Canvas Office Landscape, Caper, Celle, Co/Struc, Eames, Embody, Equa 2, Ergon 3, Ethospace, Exclave, Fine-Tune, FlexFront, Formcoat, Ground Cloth, Herman Miller Healthcare, Layout Studio, Maharam, Meridian, Mirra, Passage, Pellicle, Perspectives, PostureFit, Resolve, Sayl, Setu, Thrive, Tu, Y-Tower, and Z-Axis are among the registered trademarks of Herman Miller, Inc., and its owned subsidiaries.

™ AireWeave, Bubbletack, Cellular Suspension, Compass, Connect, DOT, Durawrap, Everywhere, Flex-Edge, Hopsak 2, Intent, Iota, Keyless Entry, Latitude, Lyris 2, Mora, Motia, Multiscrim, Nelson, Renew, Stackable, Swoop, TriFlex, Twist, and Verus are among the trademarks of Herman Miller, Inc., and its owned subsidiaries.

®Chemsurf® is a registered trademark of Wilsonart International.

Corian® is a registered trademark of E.I. du Pont de Nemours and Company Corporation.

FLEXNET™ is a trademark of Milliken & Company.

Floor Saver Glide® is a registered trademark of Carpin Manufacturing, Inc.

Geiger® is a registered trademark of Geiger International.

Microsoft® and Natural® Keyboard are registered trademarks of Microsoft Corporation.

Place Textiles® is a registered trademark of Place Textiles.